

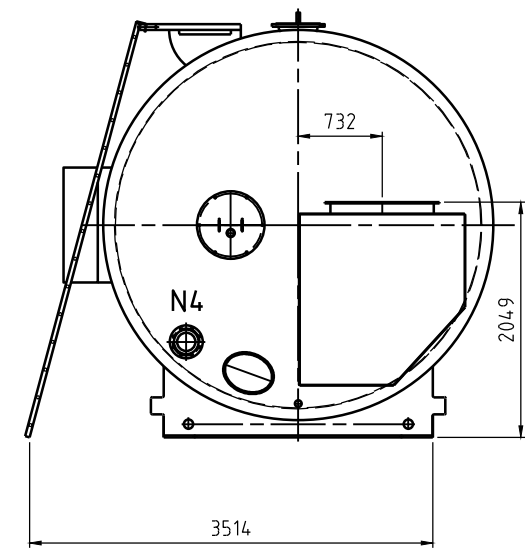

Burnerpanel frame work and platform with stairs are optional.
 Transportmass: ±24,3 t
 Heated surface: 375m²
 Watercontent: 28m³

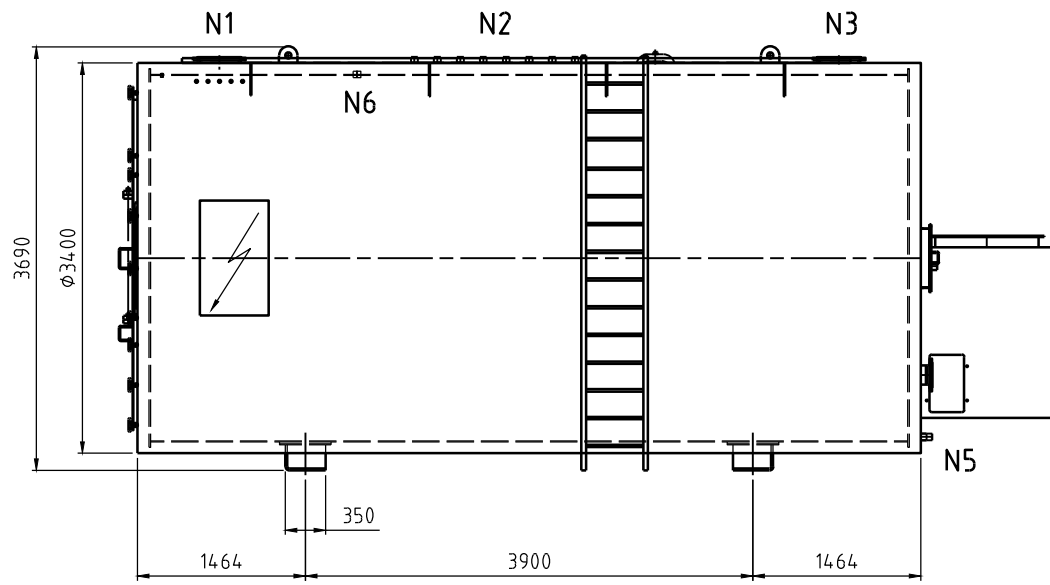
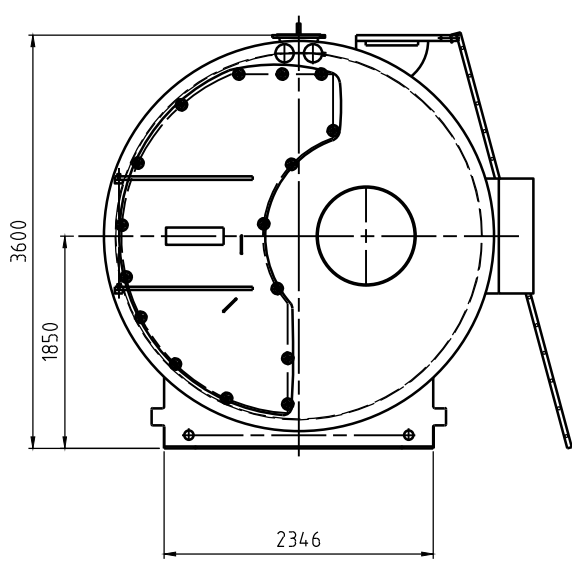
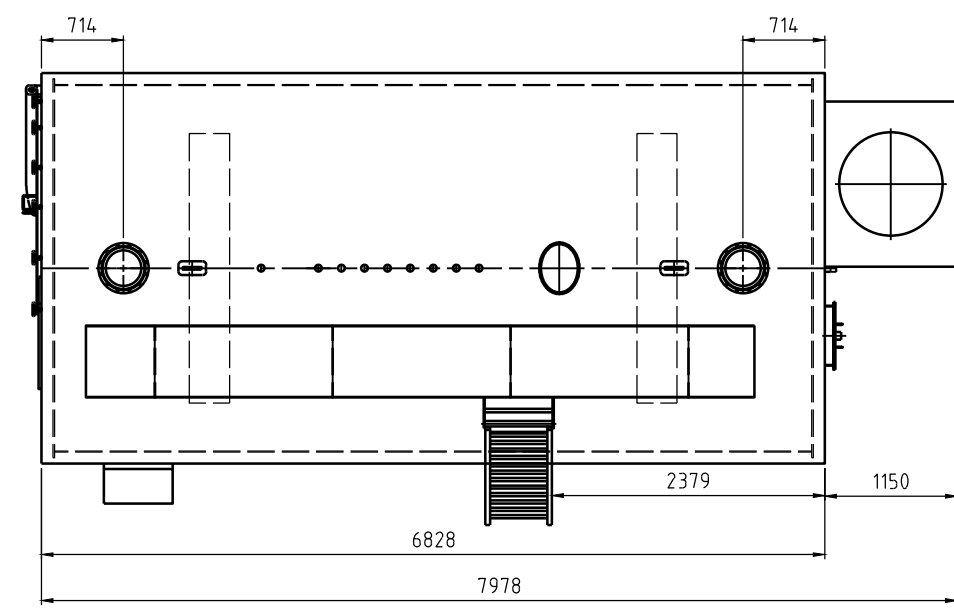

In case of an order exact boiler weight and measurements will be given on request. Subject to modifications.

NOZZLE CHART (ANSI)			
	NAME	DN	lbs
N1	SUPPLY	300	150
N2	SAFETY VALVE (8x)	2"	-
N3	RETURN	300	150
N4	SHUNT	150	150
N5	DRAIN	2"	-
N6	LOW WATER LEVEL	2"	6000

Index	Date	Drawn	Checked	Modifications
				
Drawing number:		30550800.HKB		
Title:		LNE COMPACT 11.0 ASME		
Project number:		Customer: TK-Top Boiler		
Size:	A3	Scale:	1:40	
Modification:	1	Projection:		
Drawn:	NG	Date:	24-04-2014	
Checked:	RH	Date:	24-04-2014	

The information contained in this drawing is the sole property of HKB Ketelbouw B.V. Any reproduction in part or as a whole without the written permission of HKB Ketelbouw B.V. is prohibited.



Woudeselaan 22, 2635 CH Den Hoorn, Nederland
 Telefoon: +31(0)15-2125547 Fax: +31(0)15-2840505
 E-Mail: info@tk-topboiler.nl