

Installation and maintenance
EP- 900, -1080, -1200, -1400
30 stage electric boilers

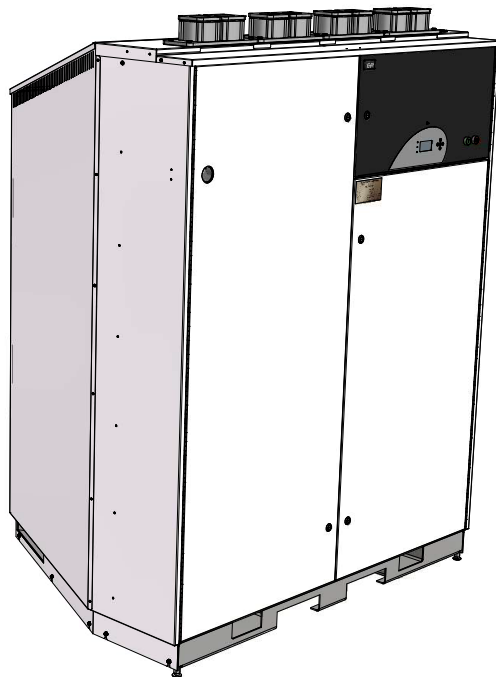

CONTENTS

Notes	3	Power supply	24
Safety and handling	4	Operating voltage	24
Operation	5	Power supply to external unit	24
Menus - standard	6	External alarm indication	24
Menus - with with OTC	7	Circulation pump	24
Operation and maintenance	8	Restart after power cut	25
Control panel	8	Reconnection	25
Operation and maintenance	9	After reconnection	25
Start - first operation	9	After reconnection	25
Adjustment menu	10	Electrical installation	25
Adjustment menu - with OTC	11	External blocking	26
Installation menu	12	External stage control	26
Information menu	14	External temperature setpoint	26
General menu	15	Output signal of connected output	26
Restart after power cut	16	Otput signal of boiler temperature	26
Power connection	16	Outdoor temperature sensor	26
Delayed power connection after power cut	16	Alternative heating - boiler with OTC	26
Quick increase/reduction	16	Wiring diagram - control circuit	28
PEC function	16	EP 900 - Power Circuit	30
Safety valves	16	EP 1080 - Power Circuit	31
Over temperature protection	16	Location on top of boiler vessel	
Maintenance	16	EP 1200 - Power Circuit	32
Cooling fan	16	Location on top of boiler vessel	
Draining	16	EP 1400 - Power Circuit	33
Action- risk of freezing	16	Location on top of boiler vessel	
Venting - water pressure	16	Technical Data	34
Checking temperature guards	17	Component Placement	36
Pressure guard(s) - option	17	Troubleshooting	38
Operation and maintenance	17	Tables for temperature sensors	38
Alarm - warning - information	18	Components	39
Red indicator flashing - alarm	18	Option	39
Yellow indicator flashing - warning	19		
Green indicator flashing - information	19		
Alarm - reset	20		
Boiler shares safety equipment	21		
Load-break switch - reset	21		
Temperature guards - Resetting	21		
Pressure guard(s) - option) - Reset	21		
Alarm - reset	21		
Water quality	22		
Water quality - suitable tap water	22		
Flow requirements	22		
System principles	23		
Open system	23		
Closed system	23		
Pipe installation	23		

Notes

Filled in when the boiler is installed!

Type: EP 900 | EP 1080 | 1200 | EP 1400 |
 Item no.: 4630 | 4632 | 4634 | 4636 |

Serial number: _____ Installation date: _____

Plumber: _____

Tel: _____

Electrician: _____

Tel: _____

Other _____

Settings

Installed power _____ kW Number of stages _____

Load guard yes no

Main fuse _____ A Primary transformer _____ (xxxx/5)

Current limit _____ A Margin _____ A

External temperature setpoint no 0 - 10 V 0 - 5 V 4 - 20 mA

External stage limit no 0 - 10 V 0 - 5 V 4 - 20 mA

Max. limit _____ °C Min. limit _____ °C

OTC - heating curve

P1 $T_{\text{outside}} = 20\text{ °C}$ _____ °C	P7 $T_{\text{outside}} = -10\text{ °C}$ _____ °C
P2 $T_{\text{outside}} = 15\text{ °C}$ _____ °C	P8 $T_{\text{outside}} = -15\text{ °C}$ _____ °C
P3 $T_{\text{outside}} = 10\text{ °C}$ _____ °C	P9 $T_{\text{outside}} = -20\text{ °C}$ _____ °C
P4 $T_{\text{outside}} = 5\text{ °C}$ _____ °C	P10 $T_{\text{outside}} = -25\text{ °C}$ _____ °C
P5 $T_{\text{outside}} = \pm 0\text{ °C}$ _____ °C	P11 $T_{\text{outside}} = -30\text{ °C}$ _____ °C
P6 $T_{\text{outside}} = -5\text{ °C}$ _____ °C	Temperature adjustment _____ °C

Safety and handling

- Read these instructions carefully before installation and operation! Keep the instructions in the boiler!
- Check that the boiler has not been damaged during transport. Report any transport damage to the carrier.
- Check that the delivery is complete.
- All installation must be performed by an authorised person in accordance with the existing regulations.
- Risk of electric shock. Never leave the boiler door open!
- Never disable the safety equipment!
- The boiler must never be switched off electrically unless the heating system is full and the boiler vented.
- Correct installation in combination with correct adjustment and continuous service will produce high operational reliability and good heating economy.
- The boiler must not be modified, changed or converted in any way.
- Only authorised persons may work on the boiler.
- Disconnect the boiler from the power supply and lock the switches before service/repairs.
- Never carry out maintenance work/service on pressure-bearing parts when they are pressurised.
- The boiler may not be used by children or people with physical or mental impairments. Nor by children/people who lack knowledge about the boiler. Children may not play with the boiler or connect accessories.
- Always contact your installation engineer for service.
- The type and production number of the boiler must always be specified when contacting Värmebaronen. See the boiler's rating plate.
- Värmebaronen AB reserves the right to change the specification, in accordance with its policy of continuous improvement and development, without prior notice.
- Subject to amendments and printing and proof-reading errors. Illustrations may differ from the actual product.

The following icons are used in these instructions to indicate important information:

 *Important information for optimum operation.*

 *Tells you what you should or should not do to avoid personal injury.*

 *Tells you what you should or should not do to avoid a component, the boiler, a process or the environment being damaged or destroyed.*

 *Electrical hazard!*

Operation

Electric boilers for heating systems or industrial processes.

The boiler's power is divided into 30 power stages.

The boilers' control range is 20-95°C.

The output of the boilers can be restricted to one power stage.

The electric boiler is manufactured in accordance with Directive 2014/68/EU, Article 4(3).

The electric boiler can be supplied with factory-fitted safety equipment, reviewed by accredited body according to EN 12828.

Final examination, under national laws, that the electric boiler has the necessary safety equipment shall be carried out by an accredited body when assessing the monitoring interval for the electric boiler.

The factory-fitted safety equipment contains safety valve(s), high-pressure guard and automatic vent valves.

Double circulation pumps and flow guards are not required. The boiler can cope with zero flow from a safety perspective.

A steam-collecting vessel is not required. The safety valves are fitted directly on the boiler's safety pipe.

Safety

The boilers have circuit breakers which are acted on via shunt release by the boiler's thermal relay, pressure guards and level protection.

The boilers do not restart automatically after a power cut.

Reliability

The boilers are equipped with leakage current measurement, which can provide an early indication of possible faults in the immersion heaters, so that faults can be quickly rectified without unplanned downtime.

Alarm indication

Alarms are indicated on the boiler's control panel.

Connection for external indication of a buzzer alarm, via alternating potential-free relay output.

Stainless steel immersion heaters

The immersion heaters are in stainless steel SS2353 with brass heads.

Pump maintenance operation

Connection for a circulation pump with pump maintenance operation.

External stage and output control

Connection for external blocking, 0 - 5 V, 0 - 10 V and 4 - 20 mA control of power.

External temperature setpoint

Connection for external setpoint in the form of 0 - 5 V, 0 - 10 V and 4 - 20 mA signal.

Output signal for present power and temperature

0 - 10 V signals for the number of power stages connected and boiler temperature.

Reconnection after power cut

Power is reconnected after a power cut according to recommendation.

Power supply to external unit

Fused 230 V~ output for supply to an external unit.

Aluminium and copper

To facilitate installation, the boilers are fitted with terminals that make it possible to connect both aluminium and copper cables. No splicing from aluminium is required.

Cooling fan

The boilers are supplied with cooling fans with air filters. If the boiler is placed in an environment with an elevated temperature or dusty environment, additional additions can be made.

Outdoor temperature compensator - OTC, option

Controls the boiler temperature in relation to the outdoor temperature via an outdoor sensor.

Series connection for greater power, option

If more power is needed, two boilers can be controlled in series.

Temperature control in secondary circuit, option

When used with, for example, a heat exchanger, the temperature in the secondary circuit can control the boiler.

The menu, standard

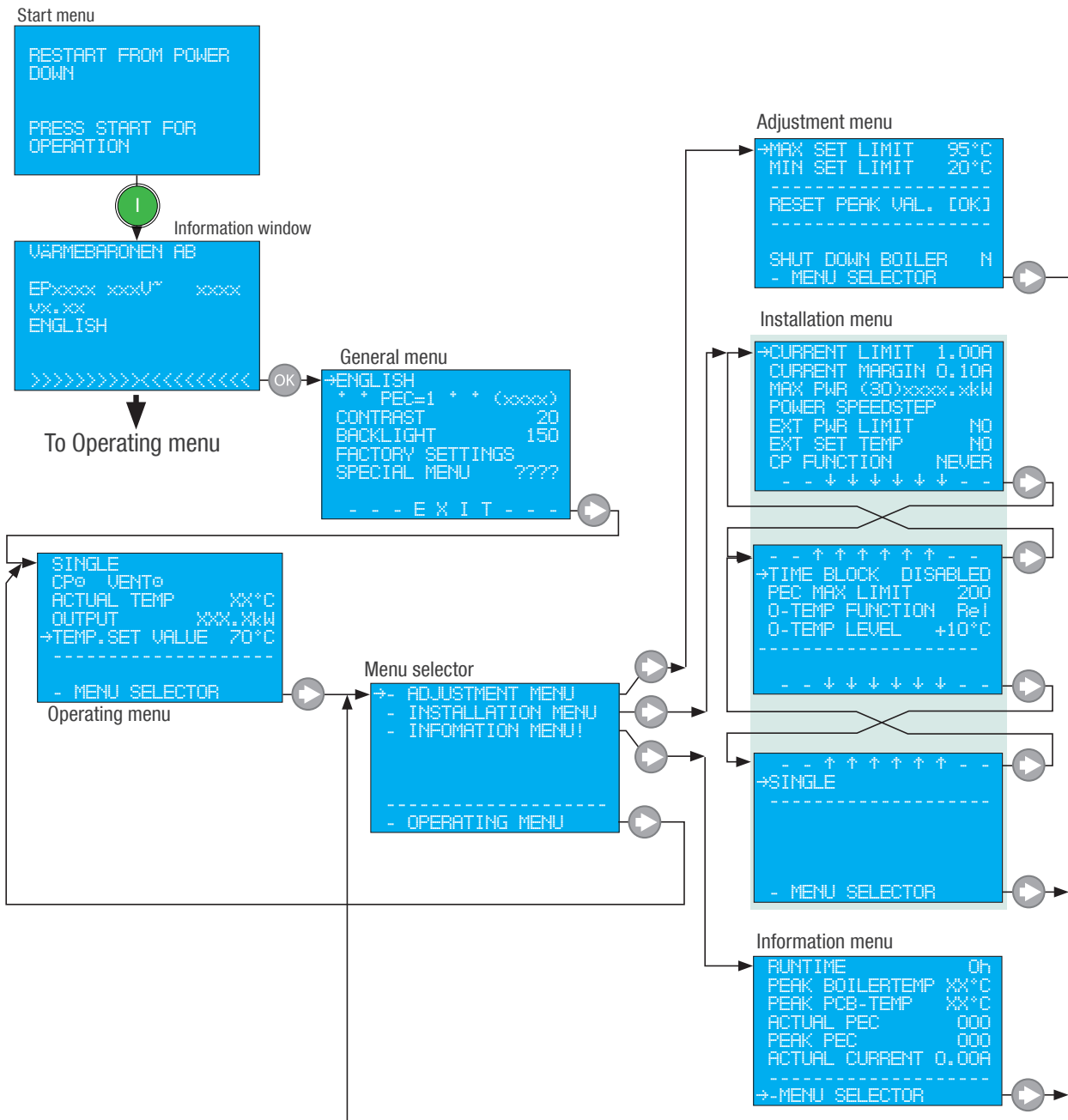

When electronics are switched on, the Start Menu is displayed.

If **OK** the information window is pressed when the arrows on the bottom row point towards the middle, the General Menu will be displayed. If is not affected, **OK** the Operating Menu is opened, which displays the boiler temperature, connected power and temperature set point.

An index arrow to the left on the line indicates that it contains information that can be changed.

↑ / **↓** moves the index arrow between the lines.

→ selects the current line.

Change the content with **↑** / **↓**.

Leave the line with **OK**.

A screen with the Menu selector is opened by moving to the bottom line with **↓** and pressing **→** there.

From this you can access the Adjustment Menu, Installation Menu and Information Menu, or return to the Operating Menu.

The procedure is the same function in the other menus.

Displayed as follows:

→ - - - E X I T - - - To Operating Menu with **→**.

→ - - ↑ ↑ ↑ ↑ ↑ - - To previous window with **→**

→ - - ↓ ↓ ↓ ↓ ↓ - - To next window with **→**

→ MENU SELECTOR To the Menu Selector with **→**

Menus - with outdoor temperature compensation (OTC)

Outdoor temperature compensation (OTC), option

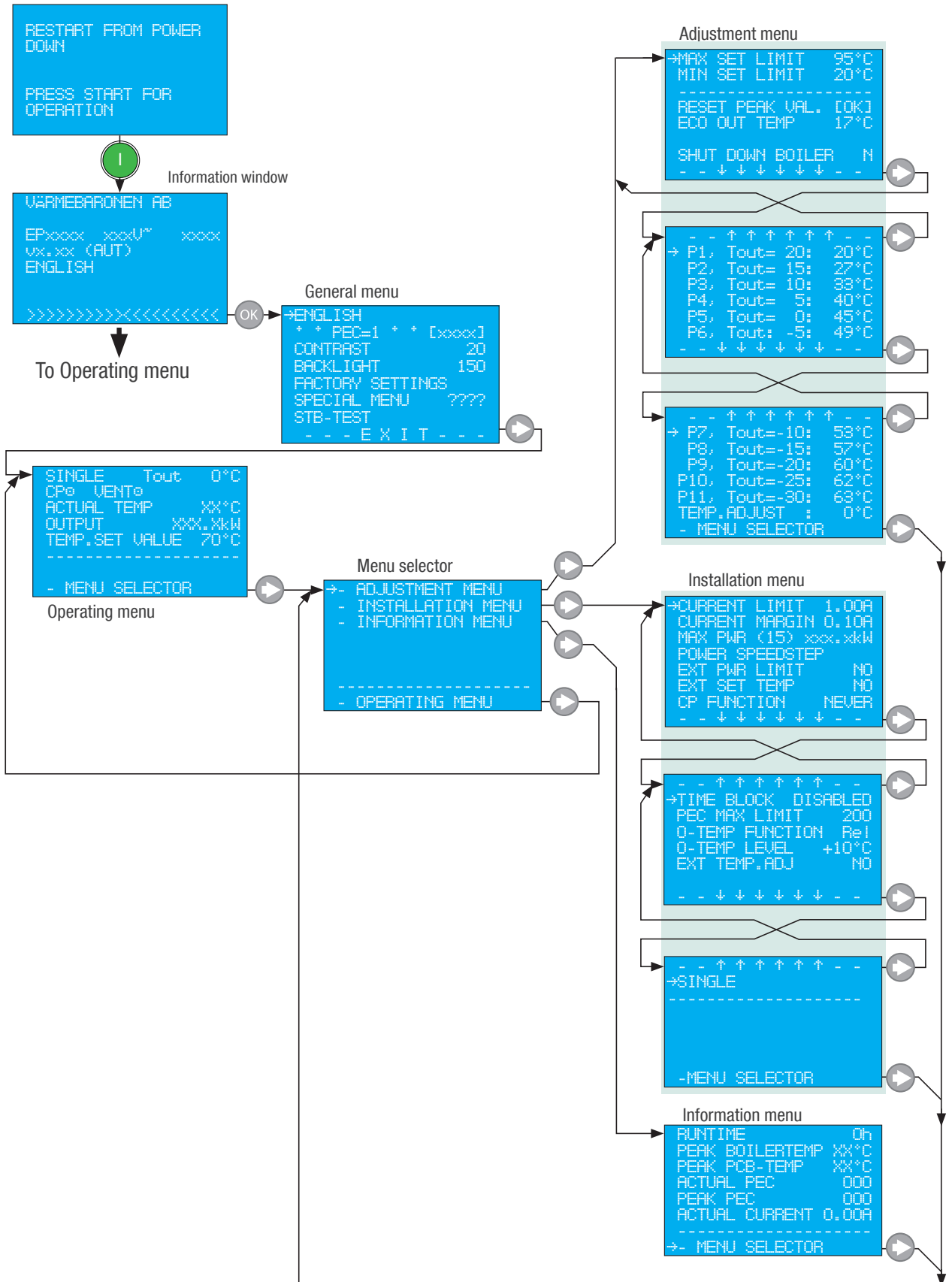



Operation and maintenance

Control panel





Red indicator

Off: normal.
Flashing: serious fault.
The display shows the cause when  is pressed.

 Moves the index arrow up between rows of editable content. Set/change the content with the UP/DOWN arrow. Parameters with a large setting range have a fast move function when the button has been pressed for a while.

Yellow indicator

Off: normal.
Flashing: warning.
The display shows the cause when  is pressed.

 Moves the index arrow down between rows of editable content. Set/change the content with the UP/DOWN arrow. Parameters with a large setting range have a fast move function when the button has been pressed for a while.

Green indicator

On: normal.
Flashing: something is preventing power increase/decrease.
The display shows the cause when  is pressed.

 Press the RIGHT arrow to select the highlighted line. Set/change the content with the UP/DOWN arrow.

 -

 Used to restart the boiler after a power cut.

 Confirms a change and jumps back to the current menu. Changes made take immediate effect when you press OK.

 Breaks the power supply to the boiler by tripping the boiler's load-break switch. The voltage to the control circuit is not broken!

Display

Shows status, alarms, etc. The display returns to the Operating menu a minute after any button has been pressed.

Operation and maintenance

Before switching on and first operation the boiler, all operating conditions must be met, check:

Power cables' connections; tighten them.

That the boiler and heating system are full of water and vented and that the air vents are open so that they can let air out.

That all necessary valves are open.

That the circulation pump is working and the flow direction is correct.

That any safety valves are working.

That no tools or similar have been left behind the busbar system.

That safety equipment is working as intended.

Start - first operation

Switch on the power to the boiler, follow the instructions in the window. Windows will not appear if the manual restart function is bypassed, see "Restart after power cut".

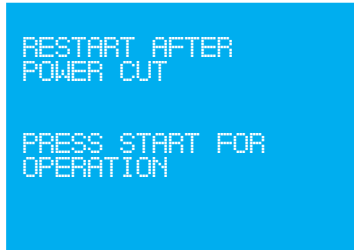

If the conditions are correct, this window is displayed for a short time. The information varies slightly with the boiler's equipment.



The Operating Menu is then displayed. The information varies slightly with the boiler's equipment.

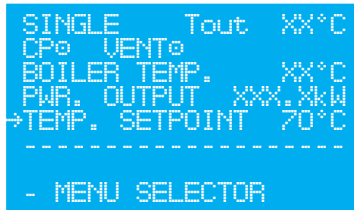

If the bottom row switches between displaying this, the cause is displayed when **OK** is held down, see "Alarm - warning - information".



When the boiler is first operated, the following parameters must be checked/adjusted. More information is available under 'Menus'. Note the settings in 'Notes'

Installation menu

Output limiting →MAX POWER (30) xxx.kW
Number of power stages the boiler should work with.



External stage limitation →EXT PWR LIMIT NO
Potential-free blocking, 0-5V, 0-10V or 4-20 mA.



External temperature setpoint →EXT SET TEMP NO
0-5V, 0-10V or 4-20 mA.



Circulation pump →CP FUNCTION NEVER
Operating options, NEVER, AUTO, ALWAYS or ECO (only with OTC, optional).



Delayed reconnection →TIME BLOCK DISABLED
Reconnection after power cut



Over temperature →O-TEMP FUNCTION Rel



Adjustment menu

Max and min setpoints →MAX TEMP SET 95°C
Limits of the range for setting the boiler's temperature setpoint.



Setting of heat curve
Boiler with OTC.

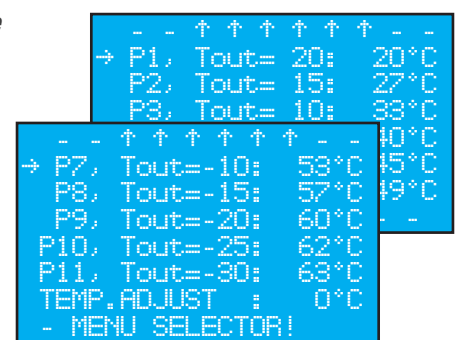

Operating menu

Boiler temperature, setpoint →TEMP. SETPOINT 70°C
Standard boiler.



Pressure guards

If the boiler was supplied with safety equipment, see 'Alarm - circuit breakers and safety guards', High-pressure guard and Low-pressure guard.

Operating menu, Adjustment menu

Operating menu

```
SINGLE Tout +XX°C
CPo VENTo
ACTUAL TEMP XX°C
OUTPUT XXX.XkW
→TEMP.SET VALUE 70°C
-----
- MENU SELECTOR
```

SINGEL

“SINGLE”, information, changes with series operation, option.

CP^o VENT^o

CP^o pump in operation.

CP flashing, pump paused.

See 'CP function' in the installation menu.

VENT^o cooling fan in operation.

VENT cooling fan paused.

ACTUAL TEMP. XX°C

Information, current boiler temperature.

OUTPUT XXX.XkW

Information, current connected power.

→TEMP.SET VALUE 70°C

Setting, desired boiler temperature, 20 - 95°C, setpoint. The setting range is affected by max. and min. limits.

The arrow at the beginning of the line does not appear if the boiler is equipped with a OTC function. In this case, the temperature is set in the Adjustment menu - with outdoor temperature compensation, OTC.

Adjustment menu

```
→MAX SET LIMIT 95°C
MIN SET LIMIT 20°C
-----
RESET PEAK VAL. [OK]
-----

SHUT DOWN BOILER N
- MENU SELECTOR
```

→MAX SET LIMIT 95°C

→MIN SET LIMIT 20°C

Max. and min. limits of the range for setting the boiler's temperature setpoint.

MAX SET LIMIT 55 - 105°C.

MIN SET LIMIT 20 - 50°C.

→RESET PEAK VAL. [OK]

Resetting all the high values in the information menu.

→SHUT DOWN BOILER N

Set boiler in standby position (switched off).

Adjustment menu - with outdoor temperature compensation, OTC

Adjustment menu - boiler with UTC - Window one

```

->MAX SET LIMIT 95°C
MIN SET LIMIT 20°C
-----
RESET PEAK VAL. [OK]
ECO OUT TEMP 17°C

SHUT DOWN BOILER N
- - ↓ ↓ ↓ ↓ ↓ ↓ - -
    
```

```

->MAX SET LIMIT 95°C
->MIN SET LIMIT 20°C
    
```

Maximum and minimum temperature setpoint.

MAX SET LIMIT 55 - 105°C.
MIN SET LIMIT 20 - 50°C.

```

->RESET PEAK VAL. [OK]
    
```

Resetting the values in the information menu.

```

->ECO OUT TEMP +17°C
    
```

Lowest temperature at which no heating is required. All boiler power disconnected, the circulation pump is stopped.

Alternative **->CP FUNCTION ECO** in the Installation menu must be selected for the ECO function to be active and for temperature setting to be carried out

```

->SHUT DOWN BOILER N
    
```

Set boiler in standby position (switched off).

Window two

Setpoint at outdoor temperature.

```

- - ↑ ↑ ↑ ↑ ↑ ↑ - -
20°C -> P1, Tout= 20: 20°C
15°C -> P2, Tout= 15: 27°C
10°C -> P3, Tout= 10: 33°C
5°C -> P4, Tout= 5: 40°C
0°C -> P5, Tout= 0: 45°C
-5°C -> P6, Tout= -5: 49°C
- - ↓ ↓ ↓ ↓ ↓ ↓ - -
    
```

Window three

Setpoint at outdoor temperature.

```

- - ↑ ↑ ↑ ↑ ↑ ↑ - -
-10°C -> P7, Tout=-10: 53°C
-15°C -> P8, Tout=-15: 57°C
-20°C -> P9, Tout=-20: 60°C
-25°C -> P10, Tout=-25: 62°C
-30°C -> P11, Tout=-30: 63°C
TEMP. ADJUST : 0°C
- MENU SELECTOR
    
```

```

->TEMP. ADJUST 0°C
    
```

Alternative temperature, against normal temperature, +/- adjustment of setpoint, parallel displacement.

The change is affected by a contact function connected to terminal block J2, see point 32 "Control circuit"

Heating curve

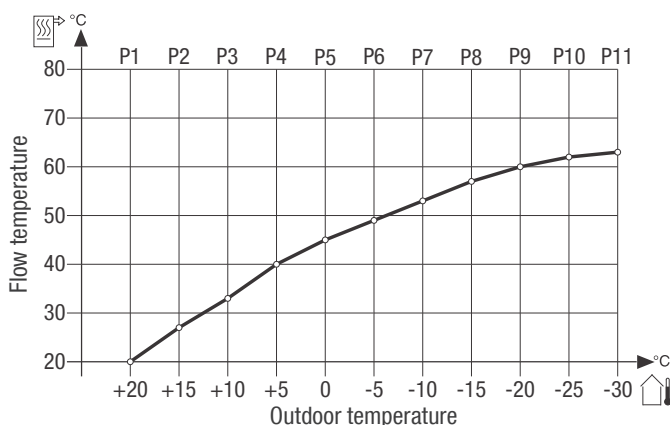

Each setpoint, P1 - P11, is adjustable over the range 20 - 80°C

Installation menu

Window one

```
→CURRENT LIMIT x.xx A
CURRENT MARGIN x.xx A
MAX PWR (30)xxxx.x kW
POWER SPEEDSTEP
EXT PWR LIMIT NO
EXT SET TEMP NO
CP FUNCTION NEVER
- - ↓ ↓ ↓ ↓ ↓ ↓ - -
```

```
→CURRENT LIMIT 1.00A
```

```
→CURRENT MARGIN 0.10A
```

No function!

```
MAX PWR (30)xxxx.x kW
```

Selection of the power with which the boiler is to operate. The figures in brackets show the number of stages.

```
→POWER SPEEDSTEP
```

Quick increase/reduction of power in connection with checks and acceleration of the delay when it is active. If the delay is active, the display shows

```
→SPEEDING TIME BLOCK
```

Release the button and press it again if you want quick increase/decrease.

```
→EXT PWR LIMIT NO
```

Stage limit with external signal, 0-100% of selected power in,

```
MAX PWR (30)xxxx.x kW
```

- NO internal limit.
- 0-5V limit with 0 - 5 V.
- 0-10V limit with 0 - 10 V or potential-free blocking.
- 4-20mA limit with 4 - 20 mA.

```
→EXT SET TEMP NO
```

Temperature setpoint via external signal.

- NO internal setpoint.
- 0-5V setpoint with 0-5 V (0 - 170°C).
- 0-10V setpoint with 0-10 V (0 - 170°C).
- 4-20mA setpoint with 4-20 mA (0 - 170°C).

```
→CP FUNCTION NEVER
```

Operating method for circulation pump supplied with power by the boiler:

- NEVER no pump operation/pump switched off
- AUTO The pump starts before power is connected and stops one minute after all power has stepped out. If the pump is not in operation, it is run once daily. In the event of over temperature, the pump starts and is in operation until the over temperature situation ends, even if all power is disconnected.
- ALWAYS Pump always in operation.
- ECO Only with OTC, option.
Pump stop with maintenance operation, when the outdoor temperature meets the set temperature according to

```
→ECO OUT TEMP +17°C
```

 in the Adjustment menu

Installation menu

Window two

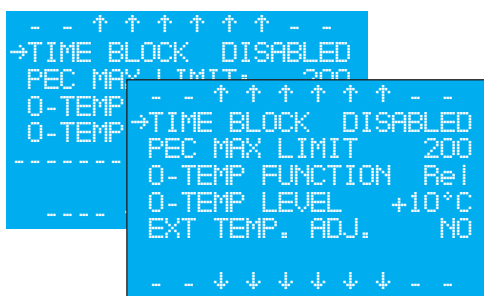

→TIME BLOCK DISABLED

Limits power connection after a power cut which has lasted longer than three minutes. See 'Delayed power connection' under "Operation and maintenance".

DISABLED no function.

ENABLED delayed output connection.

→PEC MAX LIMIT 200

Limit value, 0 - 500 quality factor, for PEC function alarm.

→O-TEMP FUNCTION Rel

→O-TEMP LEVEL +10°C

Over temperature function:

Rel over temperature relative to setpoint, 5 - 15°C.

Abs absolute value for over temperature , 35 - 105°C.

with OTC →EXT TEMP. ADJ. NO

External contact function for switching between two temperature levels.

Should the function be controlled with a closing or opening contact:

NO function is not utilised.

J2→O open contact.

J2→C closed contact.

Window three



→SINGEL

Information, changes with series operation, option.

Information menu

```
RUNTIME          0h
PEAK BOILERTEMP XX°C
PEAK PCB-TEMP   XX°C
ACTUAL PEC      000
PEAK PEC        000
ACTUAL CURRENT  0.00A
-----
->- MENU SELECTOR
```

```
RUNTIME          0h
```

The time in hours for which the electronics were powered.

```
PEAK BOILERTEMP XX°C
```

The highest boiler temperature since the electronics were last switched on.

```
PEAK PCB-TEMP   XX°C
```

The highest temperature of the relay circuit board since the electronics were last switched on.

```
ACTUAL PEC      000
```

```
PEAK PEC        000
```

Result of leakage current measurement. The value, 1 - 500, is a quality factor, i.e. the lower the value the better.

```
ACTUAL CURRENT  0.00A
```

No function!

General menu

This menu is only available on start after the electronics have been without power.

Press **OK** when this screen is shown, while the arrows in the bottom row disappear towards the centre.

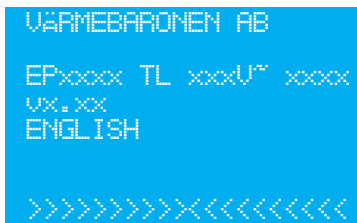

This window will then be displayed:



Language selection.



PEC=1 PEC function active.

PEC=0 PEC function disabled.

See "HIGH PEC!" Under "Alarm - warning - information".

The function is not reactivated automatically after a power cut.

(XXXX)

Information to manufacturer.



Adjusting window contrast.



Adjustment of the backlighting of the window.



Reset to factory setting.

YES OK

NO OTHER BUTTON



Manufacturer settings.



Only boiler with OTC function. Used to control the boiler's temperature guards.

Operation and maintenance



Interventions, adjustments, maintenance and the like in the boiler may only be performed by a person with authorization.

Never perform maintenance work / service on pressure-bearing parts when they are pressurized or hot.



Always cut the power to the boiler and lock the power switches before the boiler water is drained.

The control voltage is not broken by the load-break switches.

External voltage may occur.

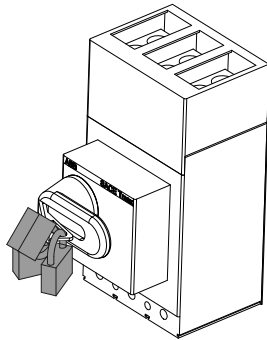

Restart after power cut

The boiler does not restart automatically after a power cut. To start the boiler, follow the instructions in the display.

Disconnection of the function must be evaluated in collaboration with the end-user and accepted by the accredited body that assesses the periodic monitoring of the boiler. See "Electrical installation".

Power connection

The boiler uses binary power increase. Thirty stages are achieved by connecting and disconnecting the power groups.

Delayed power connection after power cut

Power connection can be time restricted after a power cut, that was longer than three minutes. When the delay is active, the green indicator on the control panel flashes. Information may be displayed in the display. The delay can be temporarily disabled. See the Installation menu.

Quick increase/reduction

For quick increase/reduction, see the Installation menu.

PEC function

By measuring the leakage current of the immersion heaters, the function gives an early indication of a possible fault in the immersion heaters and thus the possibility of action without unplanned downtime.

In some installations, the measurement may give incorrect readings, caused by other equipment connected to the installation's piping and electrical system providing vagabonded leak currents. If these currents get too high, the boiler switches off even if there is nothing wrong with the boiler. If this occurs, the PEC function should be turned off. A point on insulation testing of the immersion heaters should be added to the maintenance plan. The break value for the PEC function is adjustable.

Safety valves

To maintain the safety function, the heating system's safety valves must be operated regularly.

Over temperature protection

To supplement the temperature guards, the control electronics has over temperature protection. The aim of this is to prevent the temperature guards from being tripped where possible. The protection disconnects all power in the event of a temporary temperature increase that may occur as a result of reduced flow following a pump stoppage, for example.

Maintenance

After 500 hours of operation, the cable connections must be tightened with a torque wrench.

Check the power cables' connections every 2 years.

Cooling fan

The boiler cooling fan is equipped with an air filter, which is checked regularly. The interval depends on the environment in which the boiler is installed, but at least once a year.

Draining

Always cut the power to the boiler and lock the power switches before the boiler water is drained.

Action in the event of a risk of freezing - frost protection



The boiler must not be in operation if you suspect that any part of the heating system is frozen. Call an installation engineer!

When it is extremely cold, no part of the heating system must be switched off as there is a risk of bursting. If the heating system must be switched off for long periods the system should be drained, or the heating system water can be mixed with maximum 30% glycol. When using a glycol mixture the boiler power is reduced, or the through flow in the boiler can be increased. If the heating system's water is mixed with glycol, it is important to check that the glycol contains a suitable quantity of corrosion-protection additive.

Venting - water pressure

Regularly check that the water pressure is correct. Air may be left in the system for a while after installation, for which reason it should be vented a few more times.

The boiler must not be exposed to cyclic pressure variations.

Operation and maintenance

Checking temperature guards

Stop the flow through the boiler.
Adjust the break temperature to 80°C, on the back of the temperature guards.

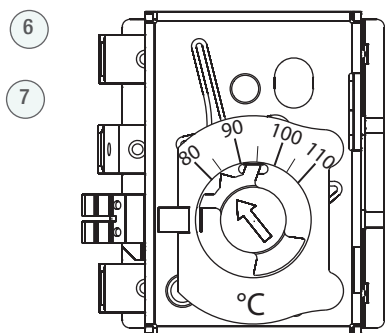

Standard boiler:

Adjust the boiler temperature setpoint to 90°C.
When the boiler temperature reaches the break temperature, the temperature guards should be triggered together with the load break switch.

Boiler with OTC:

Press the STOP button so that the load break switch trips.
Reset the load break switch so that this window is displayed:



Press **OK** when the arrows on the bottom row point towards the middle, so that this window is displayed:



Activate the function by selecting:



This window will then be displayed:

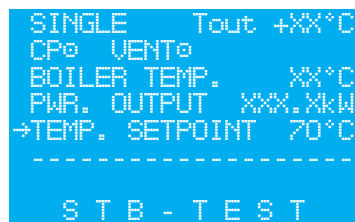

When the boiler temperature reaches the break temperature, the temperature guards should be triggered together with the load break switch.

Do not forget to readjust the temperature guards break temperature to 105°C when inspection is finished.

The break temperature must not be set lower than the boiler temperature control's highest temperature!

Pressure guard(s) - option

High pressure guard

Set so that the trigger pressure is between the boiler's normal operating pressure and the safety valves' opening pressure.

Low pressure guard

Set so that the trigger pressure is slightly below the system pressure when the system is not heated.

Adjustment

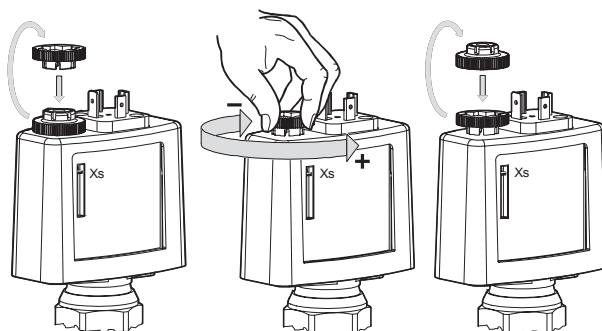

Alarm - warning - information

Red indicator flashing - Alarm

Requires action and manual reset. See "Alarm - Reset" for recovery mode. In case of a flashing red indication and the display shows:

```
ACTUAL TEMP      xx°C  
  
SWITCH IN 0 POSITION  
OR TRIGGERED  
  
SET SWITCH TO ON  
POSITION
```

- R1 **TEMPSENSOR J1** (optional)
Pt100 boiler temperature sensor, J1, see "Control circuit".
Reason: Short-circuit, interruption or not connected.
Action: Check, replace.
- R2 **TEMPSENSOR J2** (optional)
Pt100 temperature sensor, J2, see "Control circuit".
Reason: Short-circuit, interruption or not connected.
Action: Check, replace.
- R3 **TEMPSENSOR J12**
Boiler temperature sensor, J12, see "Control circuit".
Reason: Short-circuit, interruption or not connected.
Action: Check, replace.
- R4 **TEMPSENSOR J14*J9/3** (optional)
Secondary temperature sensor, J14/J9/3, see "Control circuit".
Reason: Short-circuit, interruption or not connected.
Action: Check, replace.
- R5 **TEMPSENSOR J13** (optional)
Temperature sensor cooling fan, J13, see "Control circuit".
Reason: Short-circuit, interruption or not connected.
Action: Check, replace.
- R6 **TEMPSENSOR J3** (optional OTC)
Outdoor temperature sensor, J3, see "Control circuit".
Reason: Short-circuit, interruption or not connected.
Action: Check, replace.

- R7 **TEMP SENS MAINBOARD**
Temperature sensor on power circuit board.
Reason: Short-circuit or interruption.
Action: Check, replace power circuit board

- R8 **TEMP SENS PANEL**
Temperature sensor on panel circuit board.
Reason: Short-circuit or interruption.
Action: Check, replace panel circuit board

- R9 **HIGH PEC**
Reason: The PEC value is higher than the set break limit. The function measures the boiler's leakage current, in order to give an early indication of a possible electrical heating fault.
In some systems, the measurement may give an incorrect measurement value, caused by vagabond leak currents in the plant's piping and electrical systems. See "Operation and Maintenance, PEC function".
Action: check: Current and Highest PEC value in Information menu and PEC alarm limit in Installation menu.
If the current PEC value is higher than the alarm limit, when no power is switched on, the cause is located outside the boiler. The alarm limit should then be raised approximately 50 units above the highest measured PEC value. The external leakage current should be identified and fixed. If the current PEC value is lower than the alarm limit, the fault may be in the boiler. Check:
- Acknowledge the alarm by cutting the control voltage for 10 seconds.
 - Allow the boiler to step in, while reading the current PEC value in the Information Menu.
 - To determine which immersion heater is triggering the PEC alarm, each individual immersion heater in the power group must be insulation tested.
 - If the boiler functions normally when power is switched on, without triggering PEC, the leakage current comes from an external source.
- If the cause does not depend on the boiler, the PEC function can be temporarily deactivated. See "General Menu"

- R10 **HIGH TEMP, MAINBOARD**
Reason: High temperature of power circuit board, > 30°C.
Action: Check the cause.
Highest permitted ambient temperature is ≤ 40°C.
Check that the air filter of the cooling fan is not clogged.

Alarm - warning - information

R11 HIGH TEMP. PANEL

Reason: High temperature of panel circuit board
 Action: Check the cause.
 The permissible ambient temperature is $\leq 40^{\circ}\text{C}$.
 Check that the air filter of the cooling fan is not clogged.

R12 LOW WATER LEVEL. TANK

Cause: Low water level in the boiler
 Action: Check the reason, add water and vent the system.

R13 SEE MANUAL

Cause: A guard, connected to the circuit board connections, points 15 or 16, is tripped or has lost the operating signal without tripping the power switches.
 Action: Check the cause.

Yellow or Green display flashes - warning / information

At the same time as one of the indicators, yellow or green, is flashing, the bottom line of the window alternates between:

→- MENU SELECTOR

and

PRESS OK FOR INFO

Hold  down to see the cause of the flashing.

Yellow indicator flashing - warning

Automatic reset when the cause has ceased.

Y1 PEC

Reason: Increasing PEC values, leak current.
 Action: See R9, HIGH PEC.

Y2 OVERTEMPERATURE

Cause: The boiler temperature is higher than the boiler temperature value.
 Action: Check that the boiler has sufficient flow and that all necessary valves are open.
 Check the setting for over temperature.

Y3 WATER LEVEL

Cause: Variations in the signal from the boiler's level sensor.
 Action: Check the reason, add water and vent the system.

Green indicator flashing - information

Something is preventing power increase/decrease. Automatic reset when the cause is resolved.

G1 TIME BLOCK

Cause: Delayed power connection after restart after power cut.

G2 LOAD MONITOR

Nofunction!

G3 EXT ANALOG PWR LIM.

Cause: The boiler's power increase/decrease is limited by an external setpoint or stage limit.

G4 LIMITING SET TEMP

Reason: The boiler temperature is limited by min or maximum limits of range for temperature setting .

Alarm - reset

The boiler circuit breaker can be triggered by:

- temperature/ high/ low pressure monitor in the safety circuit.
- low water level.
- high PEC value.
- interruption/short circuit in a temperature sensor.
- high temperature of power or panel circuit boards.
- safety circuit guard triggered or lost operating signal without tripping the power switches.

See "Alarm - warning - information" - "Red indication flashing - Alarm".

A buzzer alarm is issued from the boiler and a red indicator flashes on the boiler's panel.



**Always check the cause of a guard being triggered!
If a guard triggers repeatedly, the cause must be remedied!**

```
ACTUAL TEMP    xx°C
SWITCH  
H-PRESSURE GUARD
ARE TRIPPED

RESET  1.H-PRESSURE
      2.LOAD-BREAK
```

```
ACTUAL TEMP    xx°C
SWITCH  
L-PRESSURE GUARD
ARE TRIPPED

RESET  1.L-PRESSURE
      2.LOAD-BREAK
```

```
ACTUAL TEMP    xx°C
SWITCH  
H-PRESSURE GUARD  
L-PRESSURE GUARD
ARE TRIPPED
RESET  1.H-PRESSURE
      2.L-PRESSURE
      3.LOAD-BREAK
```

```
ACTUAL TEMP    xx°C
SWITCH   TEMP.GUARD
  H-PRESSURE GUARD  
L-PRESS TRIPPED
RESET  1.TEMP.GUARD
      2.L-PRESSURE
      3.H-PRESSURE
      4.LOAD-BREAK
```

Depending on the cause, the following may be displayed:

```
ACTUAL TEMP    xx°C
SWITCH IN 0-POSITION
OR TRIPPED

PUT SWITCH IN ON-
POSITION
```

```
ACTUAL TEMP    xx°C
SWITCH   TEMP.GUARD
ARE TRIPPED

RESET  1.TEMP.GUARD
      2.LOAD-BREAK
```

```
ACTUAL TEMP    xx°C
SWITCH   TEMP.GUARD
  H-PRESSURE GUARD
ARE TRIPPED

RESET  1.TEMP.GUARD
      2.H-PRESSURE
      3.LOAD-BREAK
```

```
ACTUAL TEMP    xx°C
SWITCH   TEMP.GUARD
  L-PRESSURE GUARD
ARE TRIPPED

RESET  1.TEMP.GUARD
      2.L-PRESSURE
      3.LOAD-BREAK
```

A. Reset in the order shown in the display.

B. Press the RESET button, 10, when this window appears:

```
ACTUAL TEMP    xx°C
SWITCH IN 0-POSITION
OR TRIPPED

PUT SWITCH IN ON-
POSITION!
```

See Technical Data Component Placement

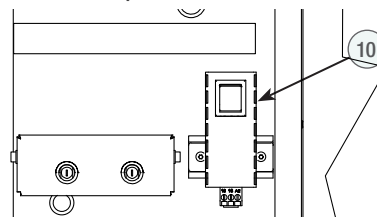

C. Reset the four load break switches. See Load-break switch.

Alarm - reset

D.The boiler software performs a restart; after a while this window appears. The information varies slightly with the boiler's equipment.

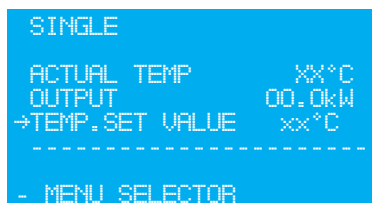

The boiler is now in operation mode unless the bottom row switches between showing:

→- MENU SELECTOR

and

PRESS OK FOR INFO

Then press  and read the cause of the alarm.

Note that the available time from pressing the RESET button until all reset should be completed is 1 minute. If the necessary measures are not taken then, the switches will release and the process must start again.

Fix the alarm and restart the boiler.

Boiler shares safety equipment

In a system in which the boiler shares safety equipment with other boilers in the system and this safety equipment is triggered, only this window can be displayed.

CURRENT TEMP 70°C
 SWITCH IN 0 POSITION
 OR TRIGGERED
 SET SWITCH TO ON
 POSITION

Load-break switch - reset

When the switches are tripped, they stand in a triggered position "tripped". A switch is reset by turning the knob to "0 off" and then to "1 on".

The version of the switch is dependent on the boiler model. The procedure is always the same!

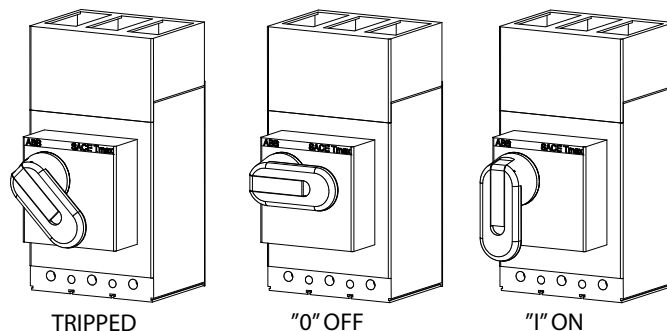

The version of the switch is dependent on the model of boiler

Temperature guard - Reset

The temperature guards, 8 and 9, trip the boiler if the boiler temperature exceeds 105°C.

Resetting is by pressing the button on the temperature guards, when the boiler temperature falls below 80°C.

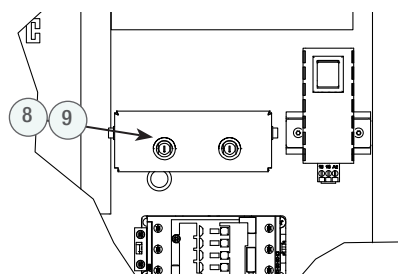

See Technical Data Component Placement

Pressure guard(s) - option) - Reset

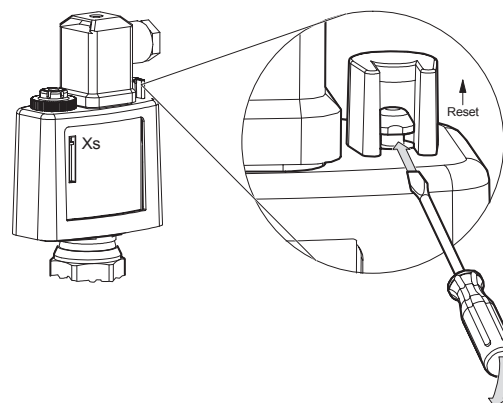

General



Installation must take place according to existing regulations and standards.

The boiler is placed standing indoors.
The installation site for the boiler must be kept free of pests.
The boiler must not be placed in spaces where explosive atmospheres may occur, such as dust or flammable gases.
The boiler must not be placed in a risk area for earthquakes or where abnormal vibrations may occur.
The installation site shall be dimensioned for the weight of the water-filled boiler.
The boiler can be placed directly on the floor level.
The room should have a floor drain.
At least 1 metre of free space shall be provided in front of the boiler.
Adjust the foot bolts so that the boiler is horizontal.
M6 bolt is available for fixing cable ladders and the like, see Technical data - component placement.
Pipes, cable ducts, etc. may not be laid on the boiler's rear cover plate.
Expansion system - The safety pipe, the boiler must be connected to an expansion system.
Valves must be fitted between the boiler and the heating system.
Pipes must be routed so that it is possible to open the front and remove the roof plate for service.
Ensure there is sufficient ceiling height to allow the immersion heaters to be changed.
The boiler is not intended for use with oxygenated water.
As frost protection, the water in the system may be mixed with maximum 30% glycol.
Heating systems can differ between countries due to climate, traditions and national regulations. In cases where the standards violate national regulations, the latter must be followed. Consider national and individual requirements.
Electric boiler supplied with safety equipment is reviewed by accredited body and is in accordance with EN 12828.
With factory-fitted safety equipment, the boiler can be installed without expansion trap.
Double circulation pumps and flow guards are not required.
The boiler can cope with zero flow from a safety perspective.
A steam-collecting vessel is not required. The safety valves are fitted directly on the boiler's safety pipe.
Final examination, under national laws, that the electric boiler has the necessary safety equipment shall be carried out by an accredited body when assessing the monitoring interval for the electric boiler.
The boiler shall be positioned so that only a person with permission has access.
All of the boiler's pipe connections must be insulated to avoid the risk of burns on hot surfaces.
Pipelines may have a maximum load of the boiler connections with 250 Nm in the radial direction or 650 Nm in the axial direction.



Do not drill into the boiler's cover plates. Cuttings can damage the boiler's electrical equipment!

Water quality

Tap water is usually classified from the point of view of hygiene. Good water classified on this basis is not automatically suitable for a heating system. To avoid problems, the water should be analysed from a technical point of view and any deviations from standard values should be adjusted. If the volume of the heating system is low, it can be filled with water that was not classified as good system water. When the water is heated, some oxygen and carbonic acid are emitted to the expansion vessel or vent valves. The remainder will react with the metals in the system. This corrosion is generally insignificant. The system must be leak proof so that the water does not need to be replaced with new water and the water is not oxygenated during installation. In practice, it is impossible to protect large systems against leaks and oxygen admission. In such cases, an oxygen-consuming agent can be added so that there is always a slight surplus in the system. These agents often contain corrosion-limiting additives.

Water quality - in respect of suitable tap water:

The alkalinity should exceed 60 mg/l to avoid corrosion. Contents of carbonic acid over 25 mg/l increase the risk of corrosion. Sulphate contents over 100 mg/l may accelerate corrosion. If the sulphate content is higher than the alkalinity, there is a risk of copper corrosion. Hard water causes boiler scale and is not suitable in a heating system. The hardness must be approx. 5 - 6 dH°. Very soft water may cause corrosion damage. Chloride contents over 100 mg/l make the water aggressive, particular when combined with lime deposits. Low pH values may cause corrosion damage. The pH value should be 7.5 - 8.5. The incidence of carbonic acid in combination with low pH and hardness values makes the water aggressive. The water must not contain sludge or other impurities.

Flow requirements

The boiler must have a sufficiently high flow to function satisfactorily. The flow must be dimensioned so that it is within specified limits; see Technical data.

Insufficient water flow can result in the following:

- The difference between the temperature setting and the actual temperature achieved in the boiler increases.
- Irregular control with increased wear on the boiler's contactors, with reduced service life as a result.

Pipe installation

Excessive water flow can result in the following:

- Vibrations in the immersion heaters with noise and reduced service life as a result.
- Unnecessary wear on the system's components.

System principles

The figures shown are system principles. The actual system must be installed according to existing standards.

Any additional equipment must be installed according to the manufacturer's instructions.

Open system

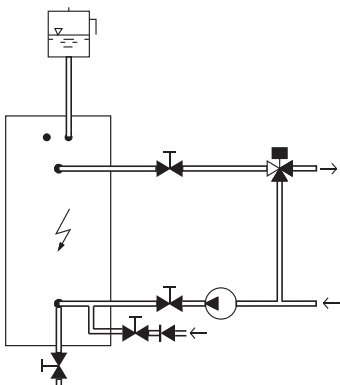

The boiler's safety line must be connected in an uninterrupted, un-closeable pitch to an expansion vessel, installed at the highest point of the heating system.

Expansion vessels are dimensioned to accommodate changes in water volume due to heating and cooling.

Expansion vessels, safety pipes, aeration and overflow pipes must be installed such that they are protected against freezing.

To avoid oxygenation of the water, the distance between the heating system's highest point and the expansion vessel must not be less than 2.5 metres.

Pressure height must exceed the pump's lowest static pressure on the low side.



To avoid damage in the event of any blockage in the expansion system, the boiler should be fitted with a safety valve.



The air vent on the boiler's safety pipe must always be open. Otherwise, air collects in the top of the boiler, which leads to disruption as the float switch is triggered on account of insufficient water level.

Closed system without a expansion trap, >300 kW, ≤105°C



The opening pressure of the safety valve is determined by the component in the system that tolerates the lowest pressure.

Under SS EN 12828, the installation must include:

- At least one safety valve min DN 15, with sufficient blow-off capacity at the system's operating pressure.
- Two pressure guards, one with zero voltage release.
- Low pressure guard if there is a risk of boiling dry, alternative to level switch.
- Two temperature guards, STB.
- Flow guard if the boiler cannot cope with zero flow.
- Valve for expansion vessel, must be locked in open position.
- For boiler placed at a higher level than consumers, a level guard is required

The boiler:

- can cope with zero flow, from a safety viewpoint
- has two built-in temperature guards.
- has a built-in level sensor.
- can be supplied with factory installed safety equipment.

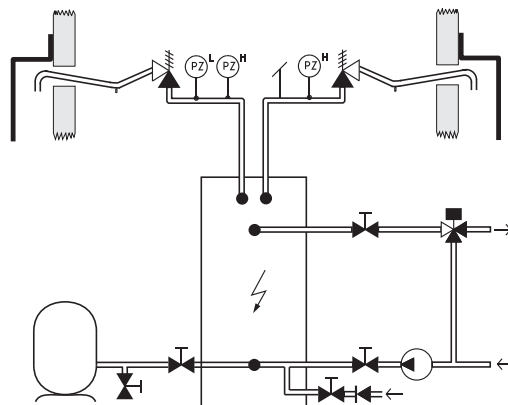

Safety valves are fitted with pressure guards and an automatic vent valve on the boiler's safety pipe.

The discharge pipe of the safety valve shall lead to a safe place in accordance with the requirements of SS EN 12828. Normally, this means on the outside of the building or in an expansion trap.

The discharge pipe from the safety valve shall be dimensioned so that the blow-off capacity is not impeded.

The discharge pipe must be laid so it cannot freeze, must be cleaned well and must be laid so that water pockets cannot form. DN 10 drainage must be provided if there is a risk of standing water in the safety valve outlet line.

Electrical installation



Electrical installation must be carried out in accordance with the applicable regulations, by an authorised electrical installer or by someone who is covered by the company's self-inspection programme!

Cables are dimensioned and installed according to current electrical installation rules.

Cables must be laid so that it is possible to open the front and remove the roof plate for service.

For minimum ceiling height, see Technical data.

Low-voltage cables may not be routed adjacent to power lines as this may give rise to interference.

The boiler and heating system must be filled with water and vented before the boiler is connected to the power supply.



Do not drill into the boiler's cover plates. Cuttings can damage the boiler's electrical equipment! M6 bolts are available for fastening cable trays.

Power supply

Removing the front roof plate facilitates the connection of the power cables.

- Loosen the screws "a", as well as the square tube that holds the doors.
- Remove the screws "b" and lift the front edge of the roof plate so that it is straight up. Then lift the roof plate straight up.
- Slide cable flanges and gaskets onto the power cables, tie them up and connect the power cables.
- Screw the cable flanges in place with the gaskets.
- Reassemble.

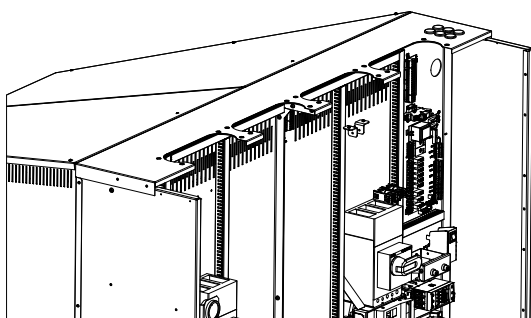
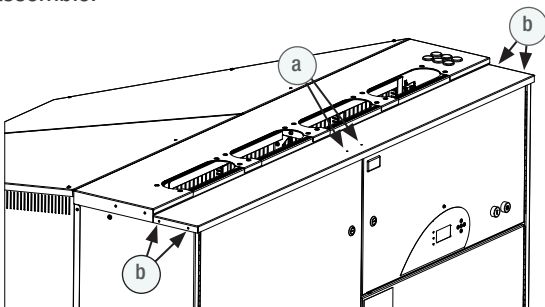

Connect PE 4-conductor cables to switches and earth terminals/clamps.

Tightening torque on switches is 31 Nm and 40 Nm on the earth clamp.

Aluminium cable must be greased with neutral contact grease.

Operating voltage

The control side of the boiler is supplied with 230V~, fused 6 A

The boiler must be preceded by an all-pole switch with at least 3 mm breaking distance!

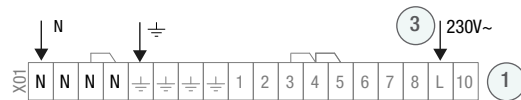

Power supply to external unit

230V~, max load 2 A



External alarm indication

Buzzer alarm for external alarm indication of low water level, overheating protection triggered, PEC or safety equipment triggered.

Potential-free alternating contact, max. 230 V~, 2 A.



Circulation pump

See 'CP function' in the installation menu!

Potential-free closing contact for control to circulation pump, max. load 230 V~, 2 A.

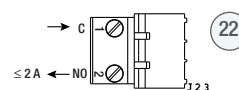

The circulation pump must be labelled to show that it is controlled by the boiler if the function is used!

Electrical installation

Pressure guards - Safety equipment

⚠ To ensure that the boiler's safety system works as intended, external safety equipment must be connected as shown below!

If the boiler was supplied without pressure guards, the installation must be supplemented with pressure guards. Connection as shown in the figure.

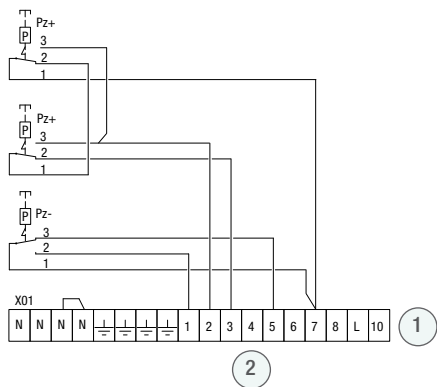

Pz- low pressure guard
Pz+ high pressure guard

Alternatively, if the boiler can share the safety equipment with other boilers in the installation.

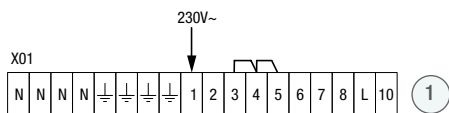

The alarm signal, 230 V~, from existing safety equipment, is connected to terminal 1.

Please note that the alarm signal must be of the same phase as that used for the boiler's control!

Restart after power cut

The boiler requires manual restart after a power cut.

⚠ Disconnection of the function must be evaluated in collaboration with the end-user and accepted by the accredited body that assesses the periodic monitoring of the boiler.

Reconnection

Move cable marked "22":

From: START button (5), clamp "13"

To: STOP button (6), clamp "14".

After reconnection:

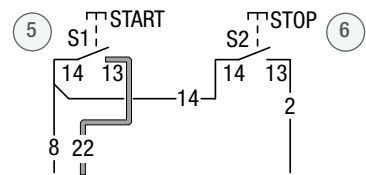

After reconnection:

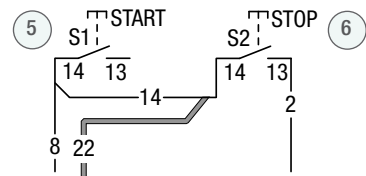

All other cables should remain in their positions!

The boiler will start automatically when the voltage returns after a voltage loss.

Electrical installation

External blocking

See 'Ext. STAGE LIMIT' in the Installation menu!

The boiler can be blocked by an external potential-free contact.

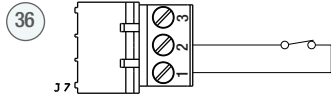

External stage control — 0 - 10 V, 0 - 5 V or 4 - 20 mA

See 'Ext. STAGE LIMIT' in the Installation menu!

0-100% of installed power. Installed power is the number of stages the boiler is permitted to use.

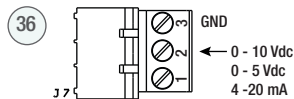

External setpoint — 0 - 10 V, 0 - 5 V or 4 - 20 mA

See 'Ext. TEMP. SETPOINT' in the installation menu!

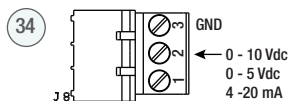

0 - 10 V output signal of connected output

0-10 V, equivalent to 0-100% of installed power.

Installed power is the number of stages the boiler is permitted to use.

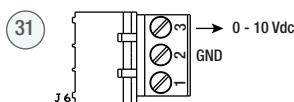

0 - 10 V output signal of boiler temperature

0- 10 V is equivalent to 0-170°C.

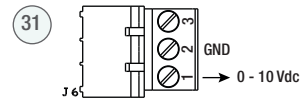

Outdoor temperature sensor - boiler with OTC

See Adjustment menu!

The temperature sensor is fitted to an outside wall, at half the height of the façade, close to a corner, facing north/north west. The sensor must not be placed where it will be exposed to the morning sun or close to valves, windows or doors.

Connection with at least 0.4 mm² cable up to 30 metres.

The duct is sealed so as to avoid condensation in the sensor enclosure.

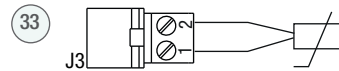



Alternative heating - boiler with OTC

See "Ext. TEMP. ADJUST" in the Installation menu and "TEMP.ADJUST" in the Adjustment menu!

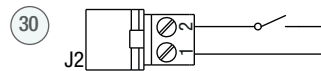
The temperature can be changed with the aid of an external potential-free contact function, protective extra low voltage.



Wiring diagram - control circuit

1. Terminal block, X01, control circuit.
2. Connection, clamps 3, 4 and 5, is removed when connecting safety equipment.
3. Connection, 230V~, voltage supply control circuit.
4. Output, 230V~, buzzer alarm.
5. 'START' button.
6. 'STOP' button. When pressed, it cuts the power supply to the boiler by tripping the load-break switches.
7. Panel circuit board with overlay.
Connected to the power circuit board, 23, via a band cable with ferrite clamps.
8. Temperature guard, one.
9. Temperature guard, two.
10. Time relay, power off delay. Used when resetting the power switches after an alarm.
11. Push button, used when resetting the power switches after an alarm.
13. Terminal block, X03, internal connection.
14. Circuit board, power.
15. Sensor inputs.
Sense the status of temperature guards and high pressure guards.
Indication lights up when:
A: the circuit board has voltage.
B: temperature guards in operating mode.
C: high pressure guards in operating mode (option).
16. Sensor inputs.
Sense the status of load-break switches, low pressure guard and zero voltage relay. Indication lights up when:
A: The power switches are in operating mode.
B: low pressure guard in operating mode (option).
C: zero voltage relay in operating mode.
17. Potential-free relay output for circulation pump, J23.
18. Cooling fans.
19. Outputs for control of semiconductor relays, SSR, optional.
20. Boiler temperature sensor, J12.
21. Temperature sensor, J13, for control of cooling fans, point 18.
22. Temperature sensor J14. Included in the boiler for secondary regulation, optional. See point 23
23. Temperature sensor J9. Alternative connection of J14, point 22. Connection to clamps 3-4.
24. Pt100 boiler temperature sensor, J1, in high temperature boilers, option.
25. Function according to option:
 - a. Alternative temperature using external contact function with outdoor temperature compensator.
 - b. Pt100 temperature sensor, J2, in high temperature boilers.
26. Output signal, current power and boiler temperature.
27. Connection for the load guard's current transformers.
 **The circuit board may be damaged, the current transformer should be short-circuited when switching on/off!**
28. Outdoor temperature sensor, J3, only together with outdoor temperature compensator, optional.
29. Connection for external setpoint setting.
30. Level sensor connection.
31. Connection for external stage control.
32. Connection of current transformer for PEC function.
 **The circuit board may be damaged, the current transformer should be short-circuited when switching on/off!**
33. Connection for panel circuit board.
- 34, 35. Connection for series control of boilers, option.
- B1. Load-break switch with auxiliary switch.
- B2. Load-break switch with auxiliary switch.
- B3. Load-break switch with auxiliary switch.
- B4. Load-break switch with auxiliary switch.
- K1. Contactor, power group one.
- K2. Contactor, power group two.
- K3, K4. Contactors, power group three.
- K5, K6, K7, K8. Contactors, power group four.
- K9, K10, K11, K12. Contactors, part of power group five.
- K13, K14, K15, K16. Contactors, part of power group five.
- K20. Zero voltage relay.

The following are included in boilers supplied with safety equipment!

36. Terminal block, X02, for pressure guards.
37. High pressure guard one.
38. High pressure guard two.
39. Low pressure guard.



The control voltage is not broken by the load-break switches! External voltage may occur.

Wiring diagram - control circuit

Pressure guards in factory-connected safety equipment.

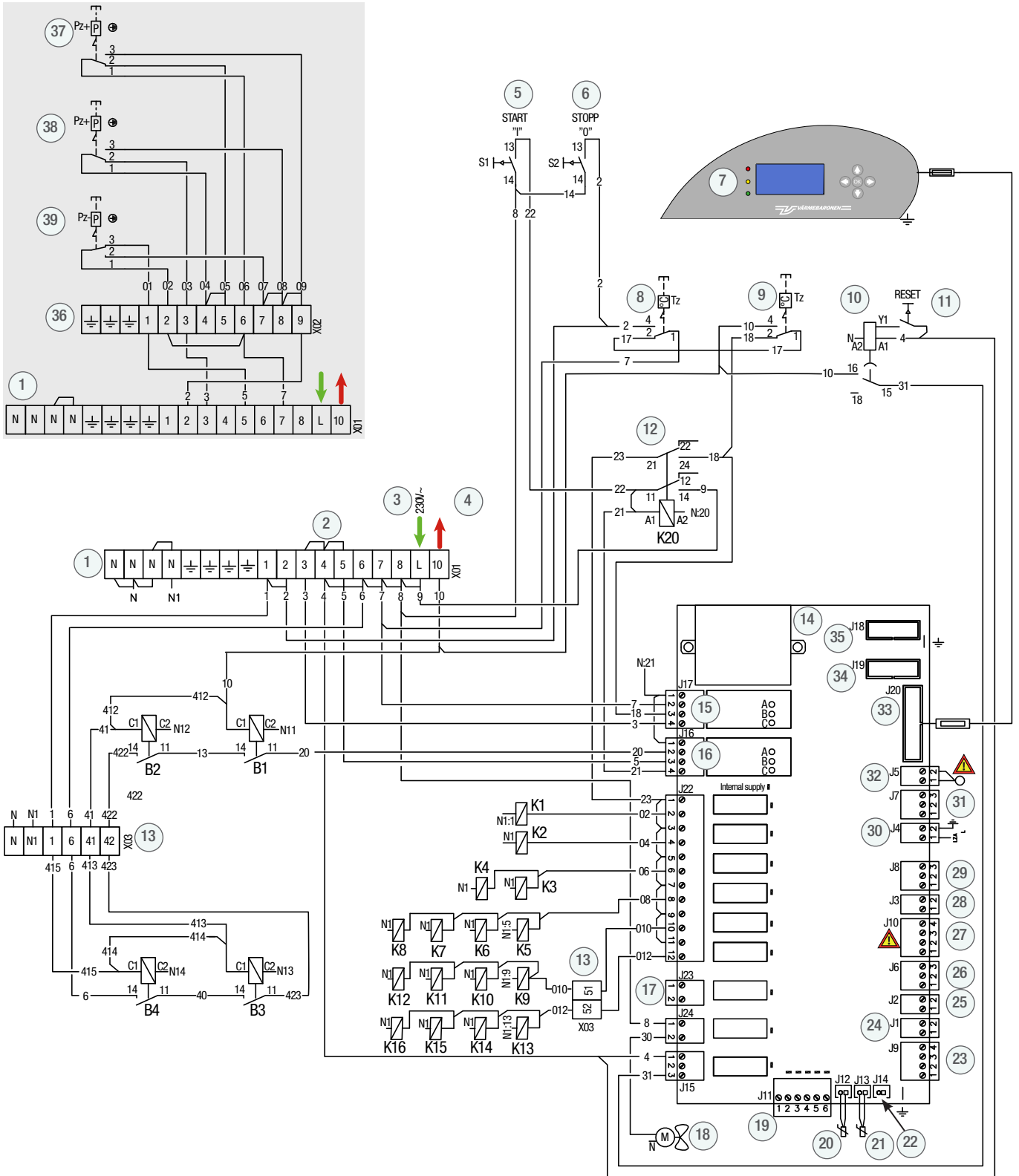

STOP Any intervention in the boiler's electrical equipment that requires tools must be carried out under the supervision of a qualified electrician!

EP 900 - Power Circuit

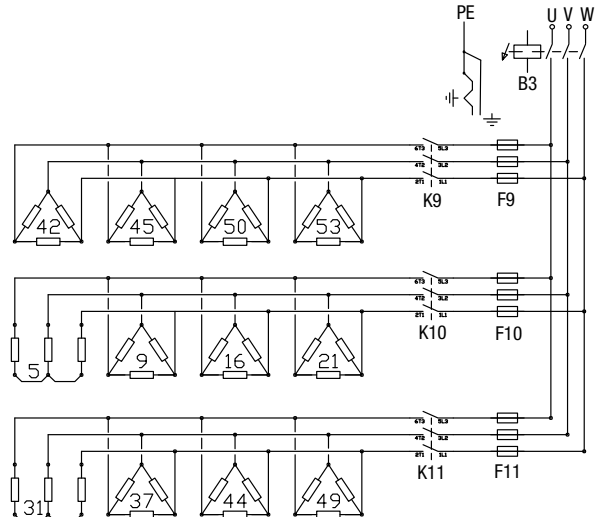
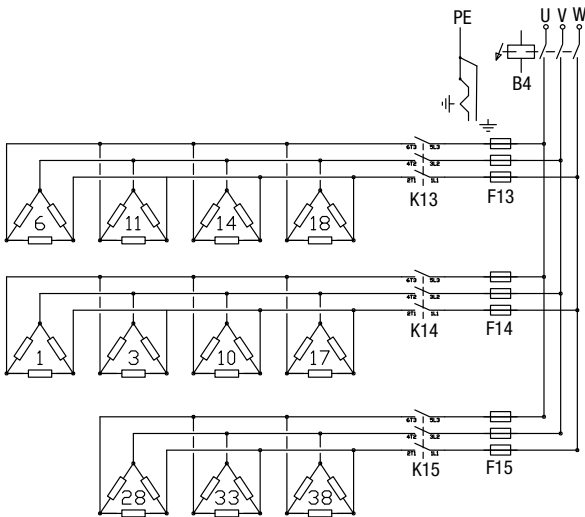
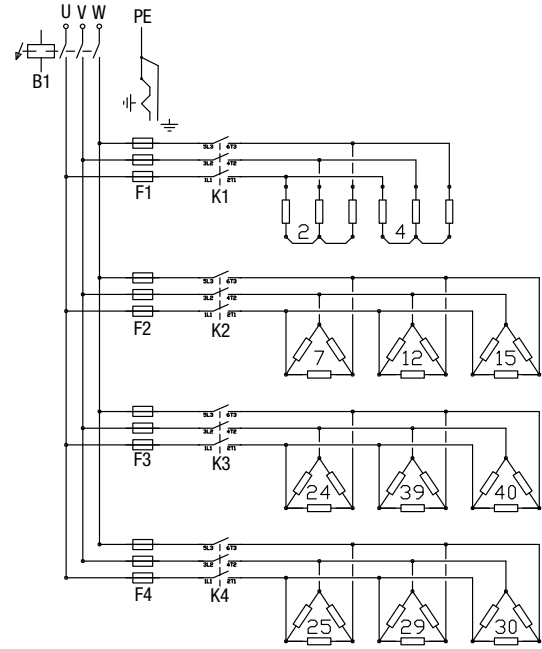
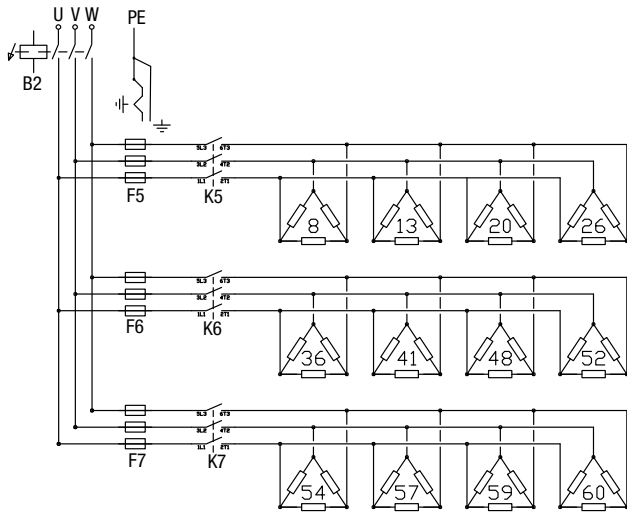

Location on top of boiler vessel
Figures state location of immersion heaters.

- A. Temperature sensor
- B. Temperature guard
- C. Manometer connection
- D. Level sensor

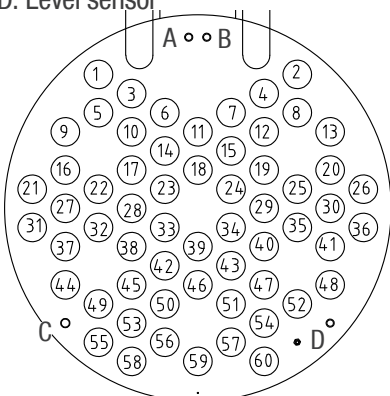

**The control voltage is not broken by the load-break switches!
External voltage may occur.**

**To break the power supply to the boiler, the load-break switches must be placed in 0 position.
Lock the switches!**

See also "Technical data - component placement"

	Power group 1 - 30 kW	Power group 2 - 60 kW	Power group 3 - 120 kW	Power group 4 - 240 kW	Power group 5 - 450 kW
Contactor	K1	K2	K3, K4	K5 - K7	K9 - K11, K13 - K15
Immersion heater					
15kW	2, 4	-	-	-	5, 31
20kW	-	7, 12, 15	24, 25, 29, 30, 39, 40	8, 13, 20, 26, 36, 41, 48, 52, 54, 57, 59, 60	42, 45, 50, 53, 5, 9, 16, 21, 31, 37, 44, 49, 6, 11, 14, 18, 1, 3, 10, 17, 28, 33, 38
Fuse					
3 x 80 A	F1	-	-	-	-
3 x 125 A	-	F2	F3, F4	-	F15
3 x 160 A	-	-	-	F5 - F7	F9 - F11, F13, F14

EP 1080 - Power Circuit

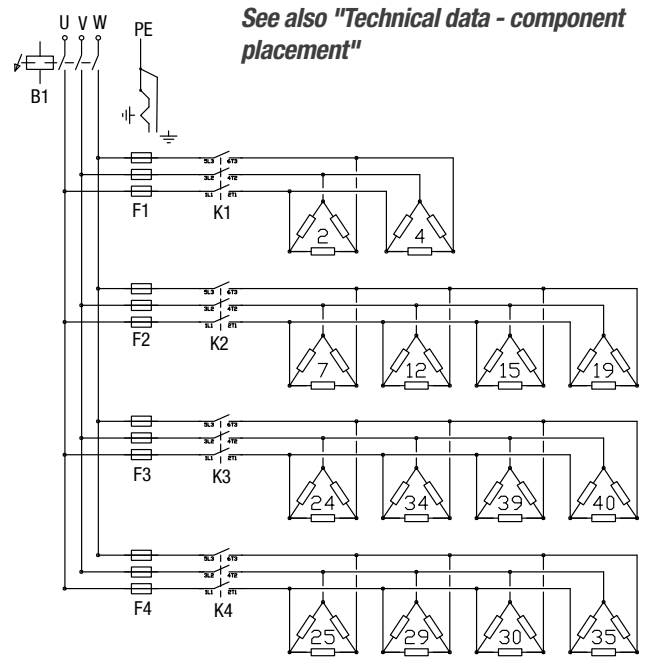
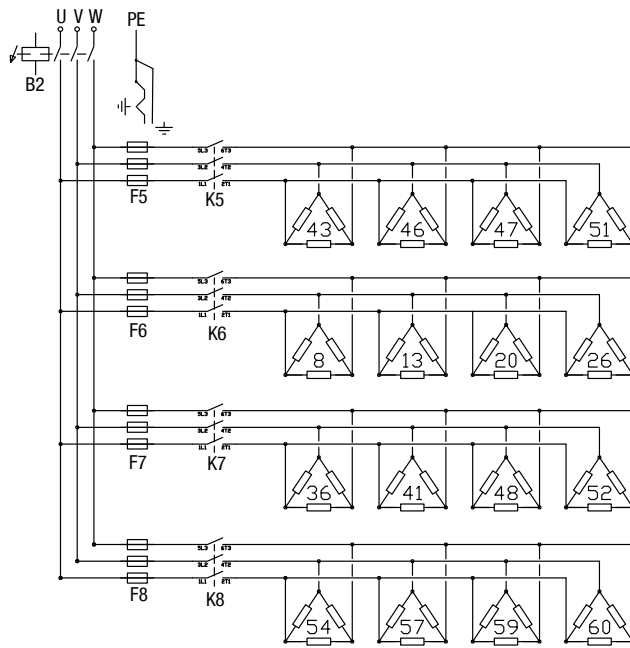

See also "Technical data - component placement"

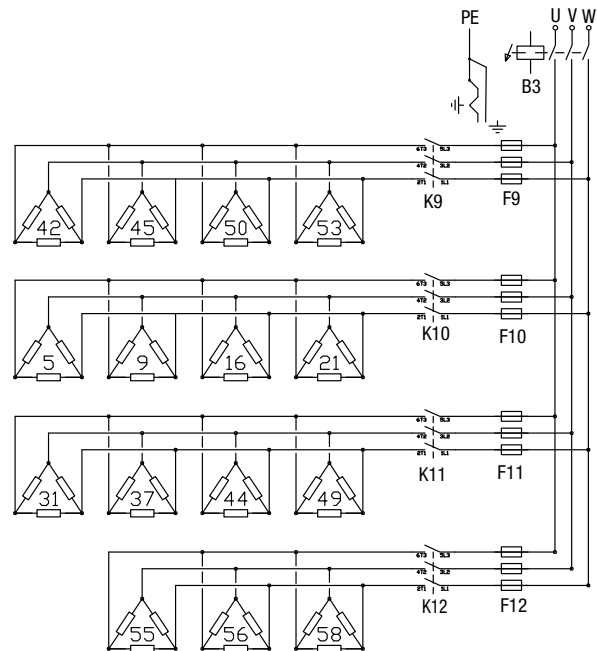
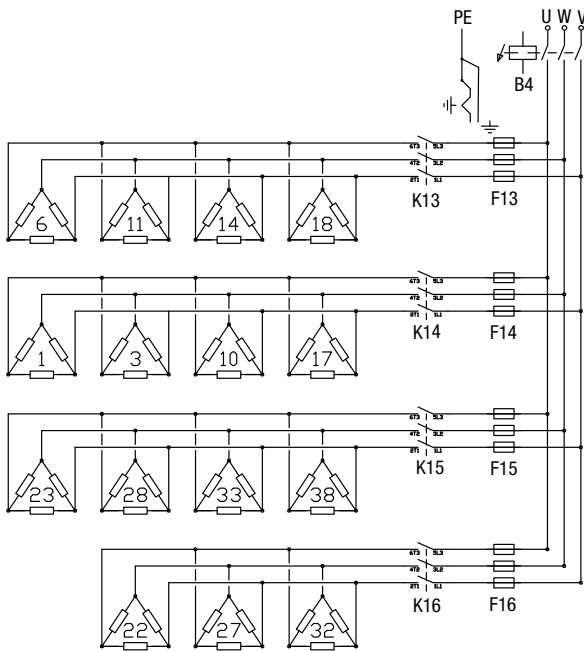

Location on top of boiler vessel
 Figures state location of immersion heaters.
 A. Temperature sensor
 B. Temperature guard
 C. Manometer connection
 D. Level sensor

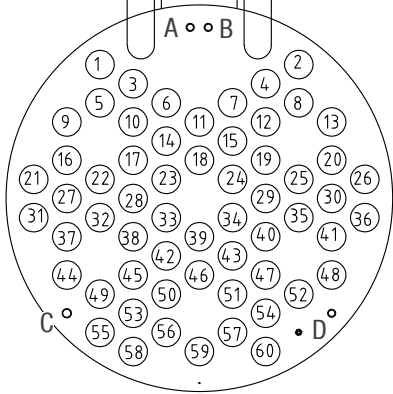

⚡ The control voltage is not broken by the load-break switches!
External voltage may occur.
To break the power supply to the boiler, the load-break switches must be placed in 0 position.
Lock the switches!

	Power group 1 - 36 kW	Power group 2 - 72 kW	Power group 3 - 144 kW	Power group 4 - 288 kW	Power group 5 - 540 kW
Contactor	K1	K2	K3, K4	K5 - K8	K9 - K16
Immersion heater					
18 kW	2, 4	7, 12, 15, 19	24, 34, 39, 40 25, 29, 30, 35	43, 46, 47, 51 8, 13, 20, 26 36, 41, 48, 52 54, 57, 59, 60	42, 45, 50, 53 5, 9, 16, 21 31, 37, 44, 49 55, 56, 58 6, 11, 14, 18 1, 3, 10, 17 23, 28, 33, 38 22, 27, 32
Fuse					
3 x 80 A	F1	-	-	-	-
3 x 125 A	-	-	-	-	F12, F16
3 x 160 A	-	F2	F3, F4	F5-F8	F9 - F11, F13 - F15

EP 1200 - Power Circuit

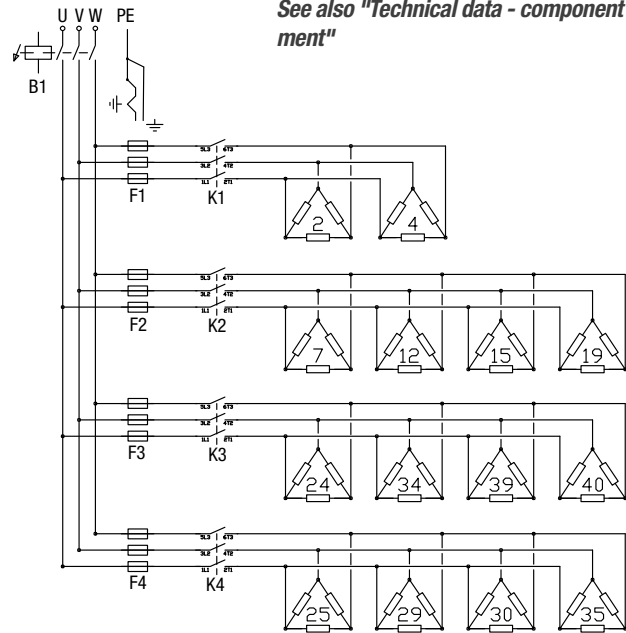
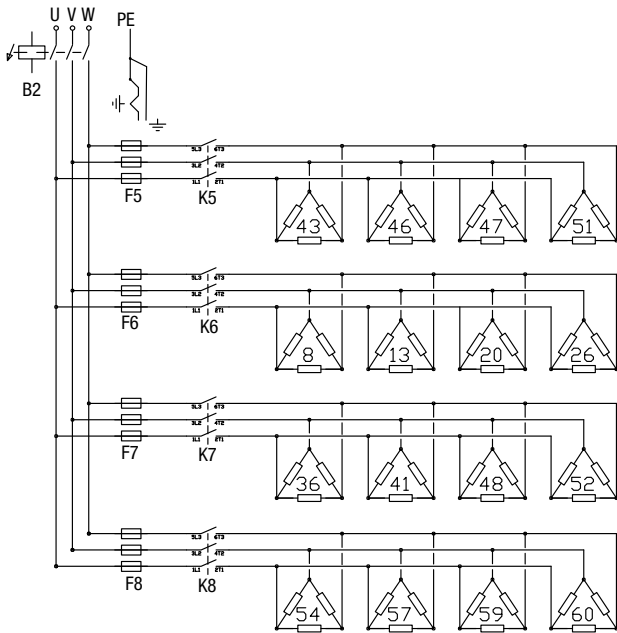

See also "Technical data - component placement"

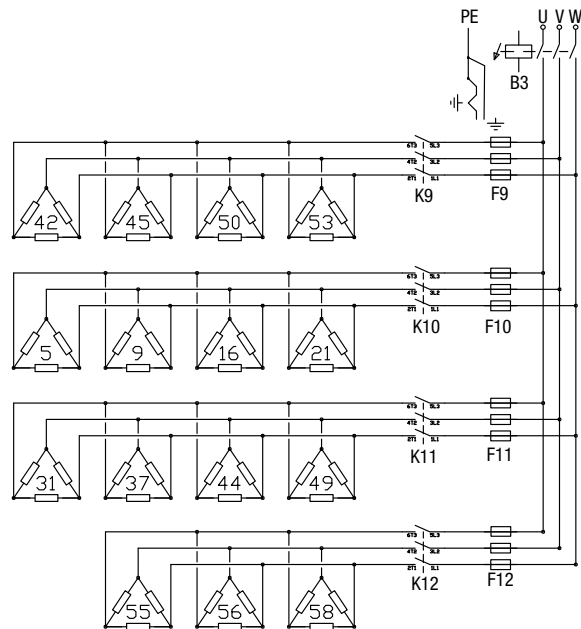
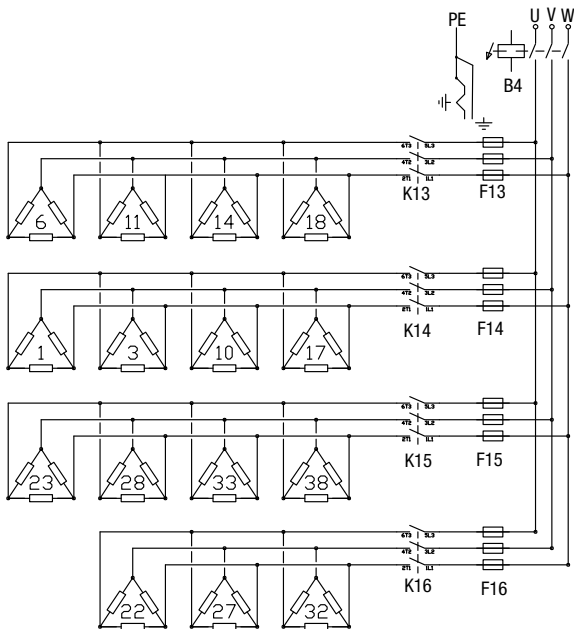

Location on top of boiler vessel
Figures state location of immersion heaters.

- A. Temperature sensor
- B. Temperature guard
- C. Manometer connection
- D. Level sensor

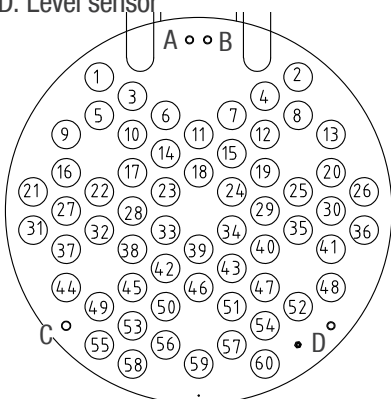

**The control voltage is not broken by the load-break switches!
External voltage may occur.**

**To break the power supply to the boiler, the load-break switches must be placed in 0 position.
Lock the switches!**

	Power group 1 - 40 kW	Power group 2 - 80 kW	Power group 3 - 160 kW	Power group 4 - 320 kW	Power group 5 - 600 kW
Contactor	K1	K2	K3, K4	K5 - K8	K9 - K16
Immersion heater					
20 kW	2, 4	7, 12, 15, 19	24, 34, 39, 40 25, 29, 30, 35	43, 46, 47, 51 8, 13, 20, 26 36, 41, 48, 52 54, 57, 59, 60	42, 45, 50, 53 5, 9, 16, 21 31, 37, 44, 49 55, 56, 58 6, 11, 14, 18 1, 3, 10, 17 23, 28, 33, 38 22, 27, 32
Fuse					
3 x 80 A	F1	-	-	-	-
3 x 125 A	-	-	-	-	F12, F16
3 x 160 A	-	F2	F3, F4	F5 - F8	F9 - F11, F13 - F15

EP 1400 - Power Circuit

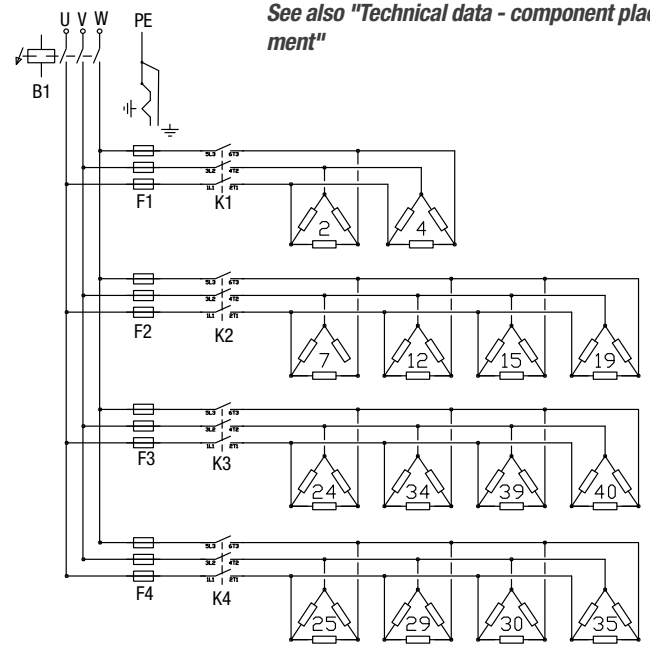
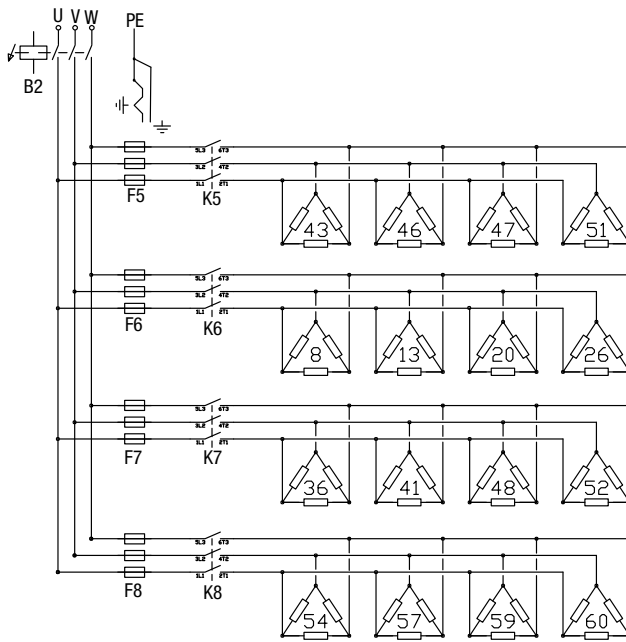

See also "Technical data - component placement"

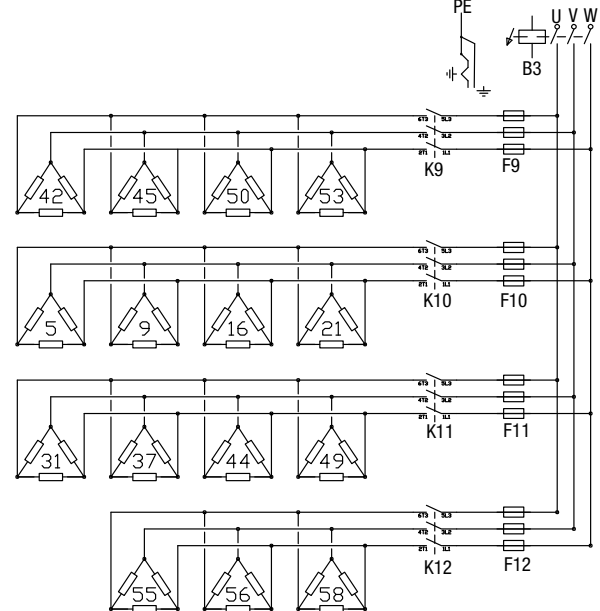
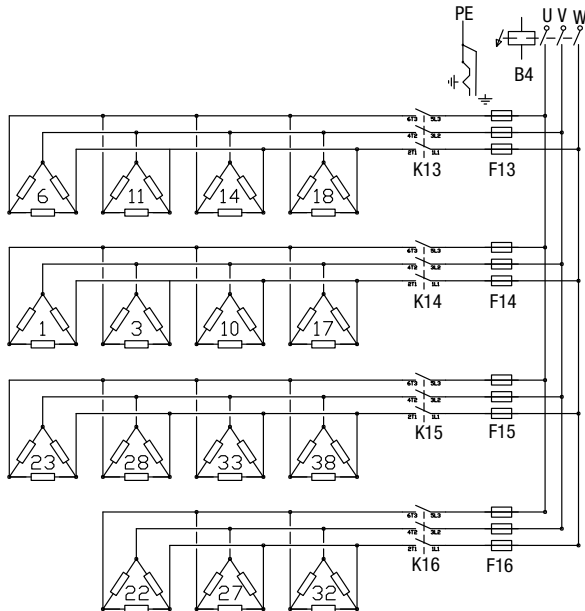

Location on top of boiler vessel
Figures state location of immersion heaters.

- A. Temperature sensor
- B. Temperature guard
- C. Manometer connection
- D. Level sensor

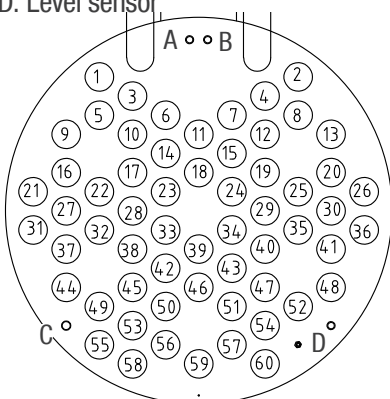

**The control voltage is not broken by the load-break switches!
External voltage may occur.**

**To break the power supply to the boiler, the load-break switches must be placed in 0 position.
Lock the switches!**

	Power group 1 - 46.6 kW	Power group 2 - 93.2 kW	Power group 3 - 186.4 kW	Power group 4 - 372.8 kW	Power group 5 - 699 kW
Contactor	K1	K2	K3, K4	K5 - K8	K9 - K16
Immersion heater					
23.3 kW	2, 4	7, 12, 15, 19	24, 34, 39, 40 25, 29, 30, 35	43, 46, 47, 51 8, 13, 20, 26 36, 41, 48, 52 54, 57, 59, 60	42, 45, 50, 53 5, 9, 16, 21 31, 37, 44, 49 55, 56, 58 6, 11, 14, 18 1, 3, 10, 17 23, 28, 33, 38 22, 27, 32
Fuse					
3 x 100 A	F1	-	-	-	-
3 x 160 A	-	F2	F3, F4	F5 - F8	F9 - F16

Technical Data

The electric boiler is manufactured in accordance with Directive 2014/68/EU, Article 4.3.

The electric boiler can be supplied with factory-fitted safety equipment, reviewed by accredited body according to EN 12828.

Factory-fitted safety equipment includes:

2 x safety valves.

2 x high pressure guards.

1 x low pressure guard.

1 x automatic vent valve.

With factory-fitted safety equipment, the boiler can be installed without expansion trap according to EN 12828.

Double circulation pumps and flow guards are not required. The boiler can cope with zero flow from a safety perspective.

A steam-collecting vessel is not required. The safety valves are fitted directly on the boiler's safety pipe.

Final examination, under national laws, that the electric boiler has the necessary safety equipment shall be carried out by an accredited body when assessing the monitoring interval for the electric boiler.

Technical data

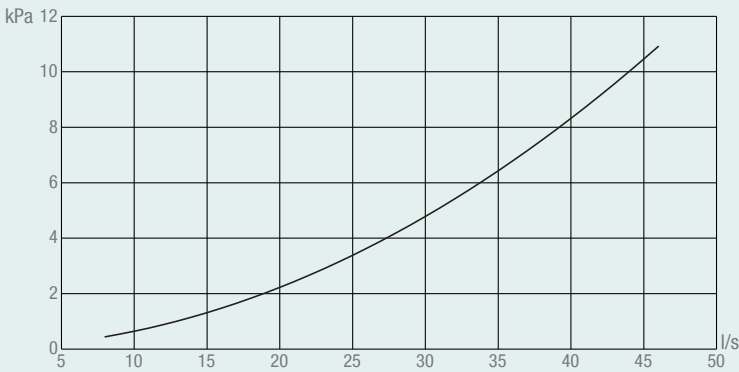
Type	EP 900	EP 1080	EP 1200	EP 1400	
Article number	4630	4632	4634	4636	
RSK					
Voltage, power control	400V3~ 230V~				
Voltage tolerance	≤ ±10				%
Frequency	50 / 60				Hz
Enclosure class	IP x1				
Output	900	1080	1200	1400	kW
Current	1299	1559	1732	2021	A
Fuse power, ≤ operation	8 groups of 200	8 groups of 250	8 groups of 300	8 groups of 315	A A
Number of stages	30, can be limited down to 1 stage				
Output/stage, stage size	30	36	40	46.6	kW
Current/stage	43.3	52	57.7	67.3	A
Cable flange	4 x FL 33, 2 x Ø60 mm				
Cable connection, area	8 x 95 - 240 Al/Cu <i>Up to 240 mm² round-pressed cable can be connected.</i>				mm ²
Volume	610				litres
Calculation pressure	0.6				MPa
	6				bar
Test pressure	0.86				MPa
	8.6				bar
Calculation temperature	110				°C
Operating temperature	20 - 100				°C
Ambient temperature	≤ 30				°C
Connection, flow/return	DN150 PN16				
Safety pipe	2 x R50 utv				
Flow requirements recommended $\Delta t=10^{\circ}\text{C}$ min/max	21.5 8.6/26.9	25.8 10.3/32.3	28.7 11.5/35.9	35.9 14.4/44.9	litres/ sec litres/ sec
Weight empty	930				kg
Weight full of water	1540				kg
Pressure drop					
Ceiling height for immersion heater replacement	>2500				mm
Manufactured to	PED 2014/68/EU article 4.3				

Technical Data - Component Placement

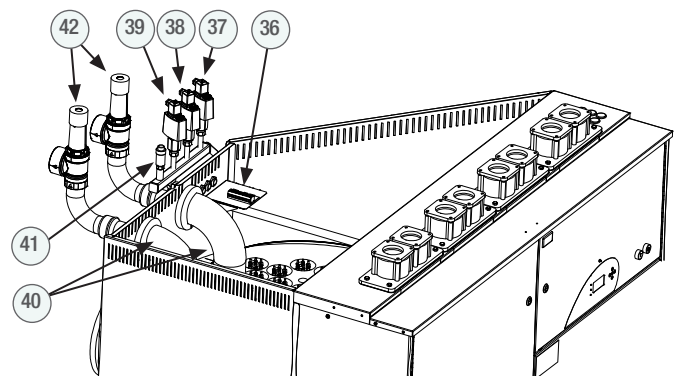
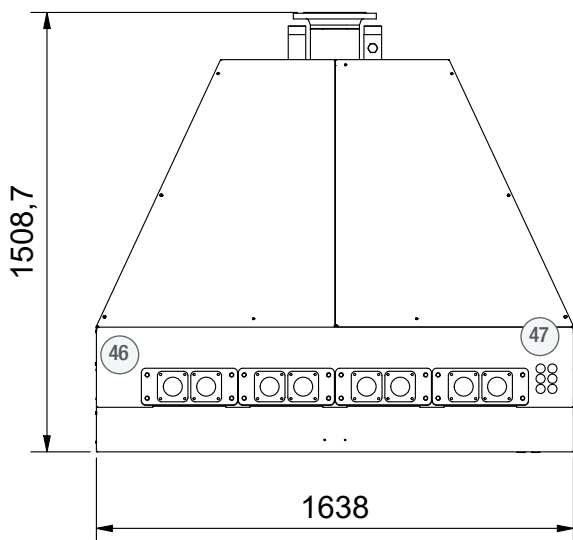
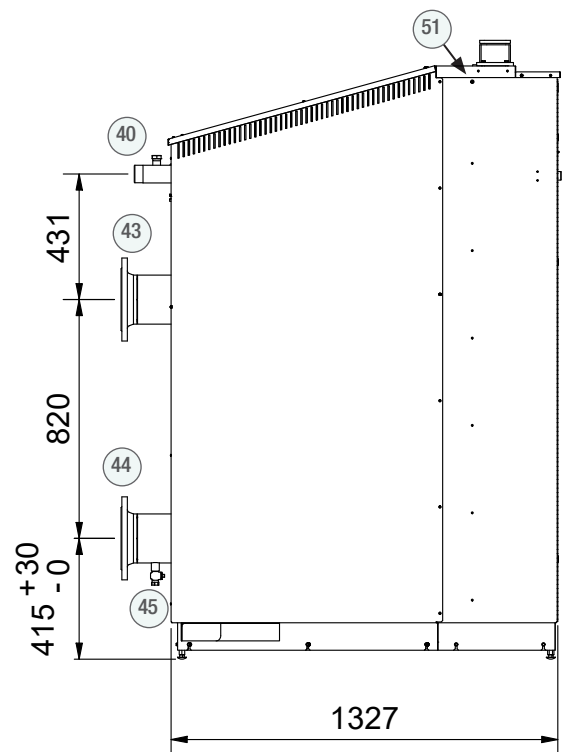
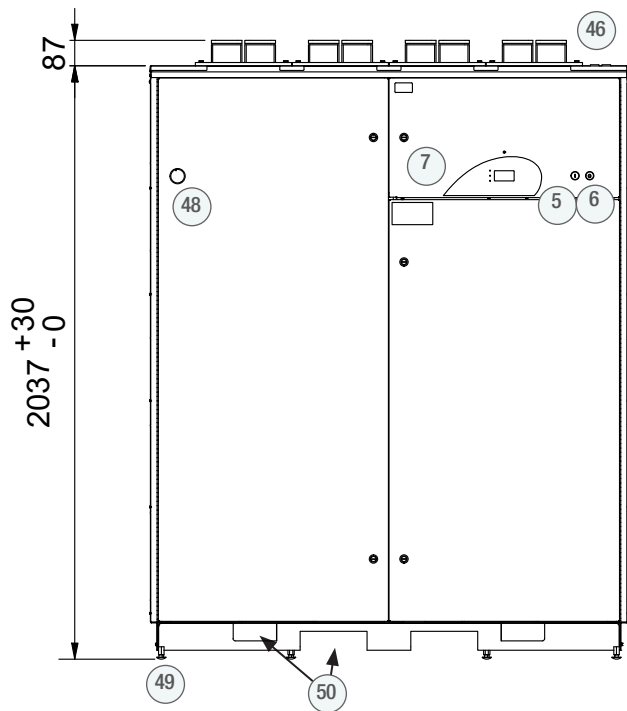

Top of boiler with cover plate removed

The figure is for illustration, there are differences between boiler models.

- 5. 'START' button.
- 6. 'STOP' button. When pressed, it cuts the power supply to the boiler by tripping the load-break switches.
- 7. Panel circuit board with overlay.
- 36. Terminal block, X02, for pressure guards.*
- 37. High pressure guard one.*
- 38. High pressure guard two.*
- 39. Low pressure guard.*
- 40. Safety pipes.
- 41. Automatic venting valve(s).*
- 42. Safety valves.*

- 43. Flow connection
- 44. Return connection.
- 45. Drain/valve.
- 46. Cable flanges.
- 47. Cable openings.
- 48. Pressure gauge, system pressure.
- 49. Adjustable foot bolts.
- 50. Socket for forklifts/pallet lifters.
- 51. M6 bolt for cable ladder bracket or similar.

* included in boilers delivered with safety equipment

Technical Data - Component Placement

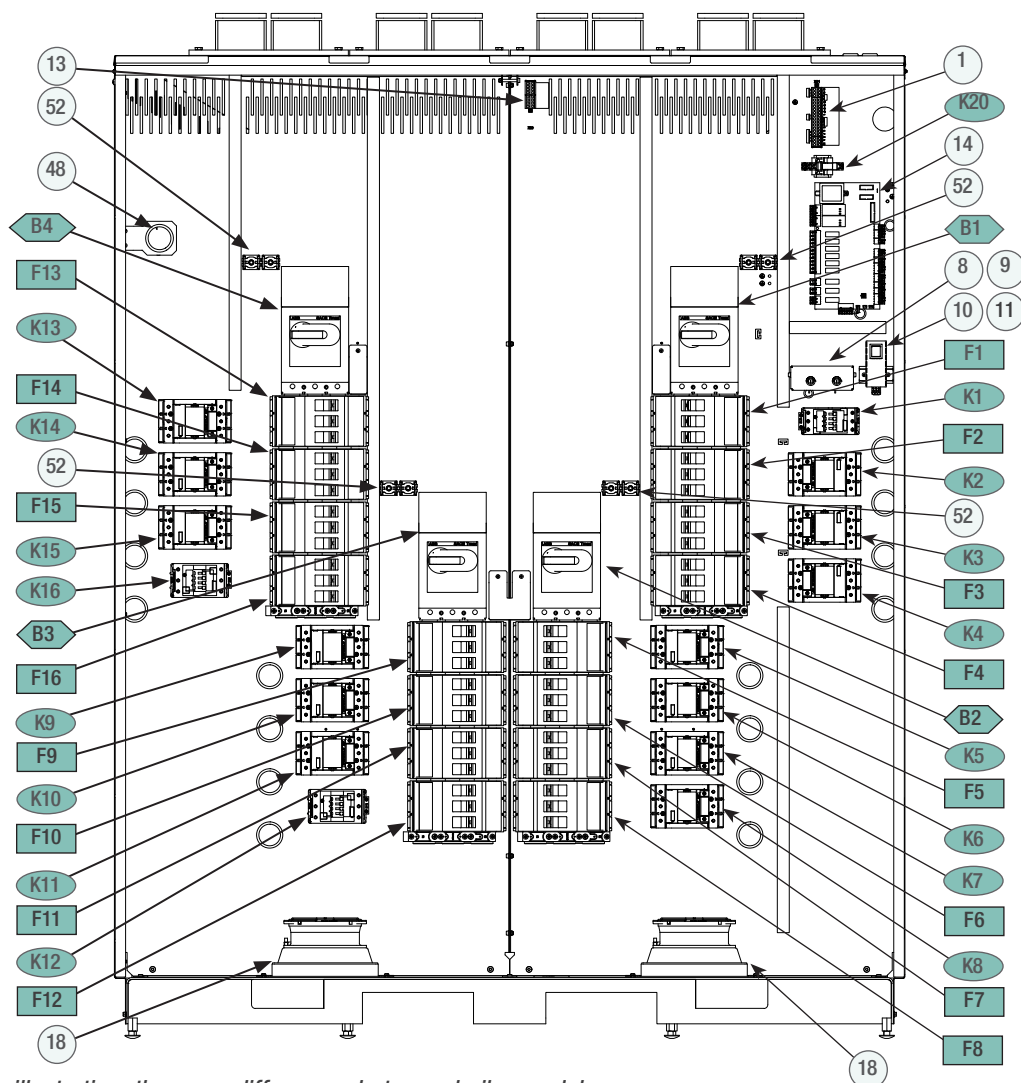

The figure is for illustration, there are differences between boiler models.

1. Terminal block, X01, control circuit.
8. Temperature guard, one.
9. Temperature guard, two.
10. Time relay, power off delay. Used when resetting the power switches after an alarm.
11. Push button, used when resetting the power switches after an alarm.
13. Terminal block, X03, internal connection.
14. Circuit board, power.
18. Cooling fans.
48. Pressure gauge, system pressure.
52. Connection, earth conductor power supply.

See also "Power Circuit" for the relevant boiler model!

- B1. Load-break switch with auxiliary switch.
- B2. Load-break switch with auxiliary switch.
- B3. Load-break switch with auxiliary switch.
- B4. Load-break switch with auxiliary switch.

- F1. Fuses power group one
- F2. Fuses power group two
- F3, F4. Fuses power group three
- F5 - F7. Fuses power group four
- F9 - F11, F13, F14, F15. Fuses power group five

- K1. Contactor, power group one.
- K2. Contactor, power group two.
- K3, K4. Contactors, power group three.
- K5, K6, K7, K8. Contactors, power group four.
- K9, K10, K11, K12. Contactors, part of power group five.
- K13, K14, K15, K16. Contactors, part of power group five.
- K20. Zero voltage relay.

Troubleshooting

Irregular operation

The electric boiler increases a few stages and is then reduced immediately, etc.

Water flow through the electric boiler too low.

Check that circulation pumps and valves are working.

This is an easy way to get an idea of the level of flow through the boiler:

- Limit the power stages of the boiler so that the power is constant, for example to one power stage.
- Let the boiler's temperature become stable.
- Measure the temperature increase between the flow and return lines of the boiler.
- Calculate the flow through the boiler using the formula below.
- Check against the details in "Data" whether the flow is adequate.

$$q = \frac{P}{\Delta t \times 1,16}$$

- q = water flow in m³/h. (m³/h x 1000/3600 = litres/second)
 P = electric boiler's power output in kW
 Δt = temperature difference between the boiler's flow and return line in °C.
 1.16 = the water's thermal absorption coefficient.

Tables for temperature sensors

When the resistance of a temperature sensor is measured, it must be disconnected from the circuit board.

For voltage measurement of sensors J12 = Boiler temperature sensor, 30.

J13 = Temperature sensor, 31, boiler with cooling fan, option.

J14 = Temperature sensor, 32, for secondary control, option. Also terminals 3 - 4 in terminal block 33.

if there are measuring points on the circuit board with connections. The voltage of other temperature sensors is measured in their connection to the terminal block.

Temperature sensors, J12, J13 and J14

°C	kΩ	V	°C	kΩ	V	°C	kΩ	V
5	141.9	4.7	45	24.6	3.6	85	5.9	1.9
10	111.6	4.6	50	20.2	3.3	90	5	1.7
15	88.3	4.5	55	16.7	3.1	95	4.3	1.5
20	70.3	4.4	60	13.9	2.9	100	3.7	1.3
25	56.3	4.3	65	11.6	2.7	105	3.2	1.2
30	45.4	4.1	70	9.7	2.5	110	2.7	1
35	36.8	3.9	75	8.2	2.3			
40	30	3.8	80	6.9	2.0			

Pt100 temperature sensor, option

°C	Ω	V	°C	Ω	V
5	101.953	0.463	85	132.8	0.586
10	103.902	0.471	90	134.702	0.594
15	105.85	0.479	95	136.603	0.601
20	107.793	0.487	100	138.5	0.608
25	109.734	0.494	105	140.395	0.616
30	111.672	0.502	110	142.286	0.623
35	113.61	0.510	115	144.175	0.630
40	115.539	0.518	120	146.061	0.637
45	117.469	0.526	125	147.944	0.644
50	119.395	0.533	130	149.824	0.652
55	121.319	0.541	135	151.701	0.659
60	123.239	0.549	140	153.575	0.666
65	125.157	0.556	145	155.446	0.673
70	127.072	0.564	150	157.315	0.68
75	128.984	0.571	155	159.180	0.687
80	130.893	0.579	160	161.043	0.694

Outside temperature sensor, option

°C	kΩ	V	°C	kΩ	V
-30	47	4.3	5	6.8	2.4
-25	34.7	4.1	10	5.4	2.1
-20	25.9	3.9	15	4.2	1.8
-15	19.5	3.6	20	3.4	1.6
-10	14.8	3.3	25	2.7	1.3
-5	11.4	3.0	30	2.2	1.1
0	8.8	2.7			

Components

EP	900	1080	1200	1400
Immersion heater				
110035 - 15kW	4	-	-	-
110037 - 18 kW	-	60	-	-
110038 - 20 kW	42	-	60	-
110039 - 23.3kW	-	-	-	60
Load-break switch				
130067 - 400A	4	-	-	-
130068 - 630A	-	4	4	4
Contactors				
170080	K5 - 7 K9 - 11 K13 K14	K2 - 11 K13 - 15	K2 - 11 K13 - 15	K2 - K16
170081	K2 - K4 K15	K12 K16	K12 K16	-
170087	K1	-	-	-
170088	-	K1	K1	K1
Blade fuse				
180063 - 80A	F1	F1	F1	-
180064 - 100A	-	-	-	F1
180065 - 125A	F2 - 4 F15	F12 F16	F12 F16	
180066 - 160A	F5 - 7 F9 - 11 F13 - 14	F2 - 11 F13 - 15	F2 - 11 F13 - 15	F2 - 16

Common components

120030	Temperature guard	2
130031	Wall-mounted switch	1
130034	Pressure switch red, "0"	1
130036	Pressure switch green, "I"	1
170008	Zero voltage relay	1
170022	Time relay	1
210313	Circuit board, power	1
210314	Circuit board, panel	1
210318	Temperature sensor circuit board	1
218010	Ferrite terminal	2
240350	Drain valve	1
300016	O-ring, non-return valve manometer	1
300017	O-ring, seal immersion heater/blind plug	1
360020	Current transformer PEC	1
380002	Non return valves	1
380023	Manometer	1
440040	Level sensor	1
700415	Overlay, panel circuit board	1
700564	Temperature sensor	1
500030	Filter fan	2
210206	Temperature sensor, fan control	1

Option

1909	UTK 7/15/30 outside temperature compensator, OTC, complete	
210211	Outside temperature sensor for OTC	
4801	Flan kit EP 135-750, one fan, complete	
4802	Flan kit EP 135-750, extra fan, complete	
500030	Fan for 4801 and 4802	1
500031	Filter for 4801 and 4802	1
210206	Temperature sensor for 4801 and 4802	1
4804	Secondary control EP31-750, complete	
210203	Temperature sensor for 4804	1
4803	Series control two boilers EP31-750, complete	

4795 Safety equipment open system, EP 350 - 750, contains:

245077	Deaerator with non-return valve	1
440196	High pressure guard	1
440197	Low pressure guard	1

Safety equipment closed system

Includes besides some of the safety valves specified below:

245077	Deaerator with non-return valve	1
440196	High pressure guard	2
440197	Low pressure guard	1
4820	EP 450, 3 bar 245515 Safety valve 3 bar DN32	2
4821	EP 600 - 900, 3 bar 245565 Safety valve 3 bar DN50/DN65	1
4822	EP 1080 - 1500, 3 bar 245565 Safety valve 3 bar DN50/DN65	2
4823	EP 450 - 600, 4 bar 245518 Safety valve 4 bar DN32	2
4824	EP 720 - 1080, 4 bar 245566 Safety valve 4 bar DN50/DN65	1
4825	EP 1200 - 1500, 4 bar 245566 Safety valve 4 bar DN50/DN65	2
4827	EP 450 - 720, 5 bar 245527 Safety valve 5 bar DN32	2
4828	EP 900 - 1200, 5 bar 245567 Safety valve 5 bar DN50/DN65	1
4829	EP 1400 - 1500, 5 bar 245567 Safety valve 5 bar DN50/DN65	2
4830	EP 450, 6 bar 245528 Safety valve 6 bar DN32	1
4831	EP 600 - 900, 6 bar 245528 Safety valve 6 bar DN32	2
4832	EP 1080 - 1500, 6 bar 245568 Safety valve 6 bar DN50/DN65	1



 **VÄRMEBARONEN**
Värmebaronen AB
Arkelstorpsvägen 88
SE-291 94 Kristianstad
Tel. + 46 44 22 63 20
www.varmebaronen.se
www.varmebaronen.com
info@varmebaronen.se